

**HIGH SPEED SINGLE NEEDLE STRAIGHT STITCHER with AUTOMATIC
THREAD TRIMMER**

**GERADSTICH-SCHNELLNÄHER mit EINFACHNADEL und
AUTOMATISCHEM FADENABSCHNEIDER**

**MACHINE A POINTS DROITS A AIGUILLE UNIQUE A GRANDE VITESSE
A COUPE-FIL AUTOMATIQUE**

**MAQUINA DE PUNTADA RECTA, DE UNA SOLA AGUJA, de ALTA
VELOCIDAD con CORTAHILOS AUTOMATICO**

DB2-B716

**PARTS BOOK
TEILEKATALOG
LIVRE DES PIECES
LIBRO DE REFERENCIA DE PIEZAS**

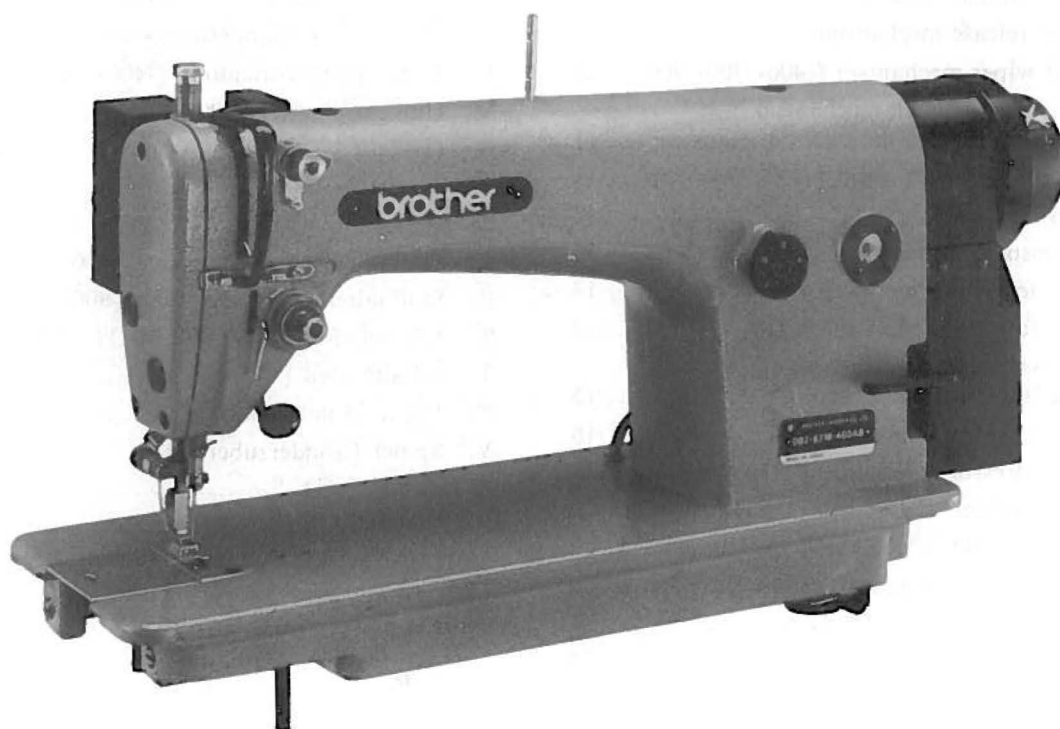

Notes for using this parts book

1. The symbol  in the "Parts No." column indicates that the parts is not available for supply. If, however, there is a number in the "Assembly No." column, the parts can be ordered as an assembly. Please, therefore, order by using the Assembly number.
2. This book was prepared based on information available in Oktober, 1983.
3. Parts are subject to changes in design without prior notice.

Anmerkungen zum Gebrauch dieses Stücklistebuches

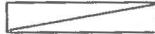
1. Dieses Zeichen  in der Spalte "Teilnummer" bedeutet, daß dieser Teil nicht lieferbar ist. Wenn jedoch in der Spalte "Gerätesatznummer" eine Nummer steht, kann dieser Teil als ein Geräteteilsatz bestellt werden. Bestellen Sie daher bitte mit dieser Gerätesatznummer.
2. Dieses Buch basiert auf den Informationen vom Oktober, 1983.
3. Modelländerungen sind vorbehalten.

CONTENTS

A. Machine body	1
B. Threading mechanism	2
C. Needle bar and thread take-up mechanism ...	3
D. Rotary hook mechanism	4
E. Feed mechanism (1)	5
E. Feed mechanism (2)	6
F. Pressure foot mechanism.....	7
G. Knee lifter mechanism	7
H. Lubrication	8
J. Thread trimmer mechanism	9
K. Tension release mechanism	10
L. Thread wiper mechanism [-400·-700·-900]... ..	10
M. Quick reverse switch mechanism [-400·-700·-900]	11
N. Quick reverse mechanism [-400·-700·-900] ..	11
P. Synchronizer	12
Q. Air pressure mechanism [-700].....	13
R. Presser foot lifter mechanism (1) [700]	14
R. Presser foot lifter mechanism (2) [-900]	14
S. Knee switch mechanism [-700·-900 BROTHER Motor]	15
T. Control box mechanism [-900]	16
U. Treadle pressure mechanism [Option parts]	17
V. Bobbin winder mechanism [Option parts] ..	18
Z. Accessories (1)	19
Z. Accessories (2) [Option parts]	20
INDEX	21
GAUGE PARTS LIST	24

INHALTSVERZEICHNIS

A. Maschinengehäuse	1
B. Fadenführungsvorrichtung	2
C. Nadelstange und Fadenabnahme vorrichtung	3
D. Greifervorrichtung	4
E. Transportvorrichtung (1)	5
E. Transportvorrichtung (2)	6
F. Stoffdruckerfuß	7
G. Kniehebel	7
H. Schmierung	8
J. Fadenabschneidevorrichtung	9
K. Spannungsverminderungsvorrichtung	10
L. Fadenspannvorrichtung [-400·-700·-900]	10
M. Umkehrschalter [-400·-700·-900]	
N. Umkehr [-400·-700·-900]	
P. Synchronisator	
Q. Luftdruck [-700]	
R. Stoffhalterhebervorrichtung [700]	14
R. Stoffhalterhebervorrichtung [900]	14
S. Knieschalter [-700·-900 BROTHER Motors]	15
T. Schaltkasten [-900]	16
U. Pedal [Sonderzubehör]	17
V. Spuler [Sonderzubehör]	18
Z. Zubehör (1)	19
Z. Zubehör (2) [Sonderzubehör]	20
VERZEICHNIS	21
LISTE DES PIÈCES DECARTEMENT.....	24

Notes sur l'utilisation de ce manuel de pièces détachées

1. Le symbole  dans la colonne "N° de pièce" signifie que la pièce ne peut être fournie. Si, dans la colonne "N° jeu de pces", il y a un numéro de nomenclature, la pièce peut être commandée comme faisant partie d'un jeu de pièces. Donc, pour toute commande, veuillez spécifier le n° du jeu de pièces.
2. Ce manuel a été fait d'après les renseignements valables au mois de Octobre, 1983.
3. Les pièces peuvent être sujettes à des modifications sans préavis.

Notas para usar este Libro de Piezas

1. El símbolo , que se encuentra en la columna del "Número de Pieza", quiere decir que no se dispone de dicha pieza sola. Cuando, empero, hay un número en la columna del "Número de Juego", se podrá ordenar la pieza con todo el juego. Por lo tanto, será mejor hacer el pedido recurriendo al número del juego respectivo.
2. Este libro ha sido compilado basándose en los datos de que se disponía en octubre de 1983.
3. Las piezas quedan sujetas a cambios de diseño sin aviso previo.

TABLE DES MATIERES

A.	Corps de la machine	1
B.	Mécanisme de J'enfilage.....	2
C.	Mécanisme de la barre à aiguille et releveur de fil	3
D.	Mécanisme du crochet rotatif	4
E.	Mécanisme de l'entraînement (1)	5
E.	Mécanisme de l'entraînement (2)	6
F.	Mécanisme du pied presseur	7
G.	Mécanisme de genouillère	7
H.	Lubrification	8
J.	Mécanisme de coupe-fil	9
K.	Mécanisme de relâche-tension	10
L.	Mécanisme de tire-fil [-400.-700.-900]	10
M.	Mécanisme de interrupteur de marche arrière rapide [-400.-700.-900]	11
N.	Mécanisme de marche arrière rapide [-400.-700.-900]	11
P.	Synchronisateur	12
Q.	Mécanisme de la pression d'air [-700]	13
R.	Mécanisme de leveur du pied presseur [-700]	14
R.	Mécanisme de leveur du pied presseur [-900]	14
S.	Mécanisme de interrupteur de genou [-700.-900 BROTHER Moteur]	15
T.	Mécanisme du boîtier de contrôle [-900]	16
U.	Mécanisme de la pédale [Pièces en option]..	17
V.	Mécanisme du bobineur [Pièces en option]..	18
Z.	Accessoires (1)	19
Z.	Accessoires (2) [Pièces en option]	20
	INDEX	21
	LEHREN LISTE	24

INDICE

A.	Cuerpo de la máquina	1
B.	Mecanismo de la enhebrado	2
C.	Mecanismo de la barra de aguja y tirahilos .	3
D.	Mecanismo del cangrejo	4
E.	Mecanismo de la alimentación (1)	5
E.	Mecanismo de la alimentación (2)	6
F.	Mecanismo del prensa telas	7
G.	Mecanismo de levantador de rodilla	7
H.	Lubricacion	8
J.	Mecanismo de recortadora de orill	9
K.	Mecanismo de liberador de tensión	10
L.	Mecanismo de limpiador de hilos [-400.-700.-900]	10
M.	Mecanismo de conmutador de inversion rápida [-400.-700.-900]	11
N.	Mecanismo de inversión rápida [-400.-700.-900]	11
P.	Sincronizador	12
Q.	Mecanismo de la presión de aire [-700]	13
R.	Mecanismo de levantador del prensa telas [-700]	14
R.	Mecanismo de levantador del prensa telas [-900]	14
S.	Mecanismo de conmutador de rodilla [-700.-900 BROTHER Motor]	15
T.	Mecanismo del caja de controles [-900]	16
U.	Mecanismo de la pedal [Piezas opción]	17
V.	Mecanismo del devanador de la canilla [Piezas opción]	18
Z.	Accesorios (1)	19
Z.	Accesorios (2) [Piezas opción]	20
	INDICE	21
	LISTA DE PIEZAS CALIBRADORAS	24

A. Machine body/Maschinengehäuse
 Corps de la machine/Cuerpo de la maquina

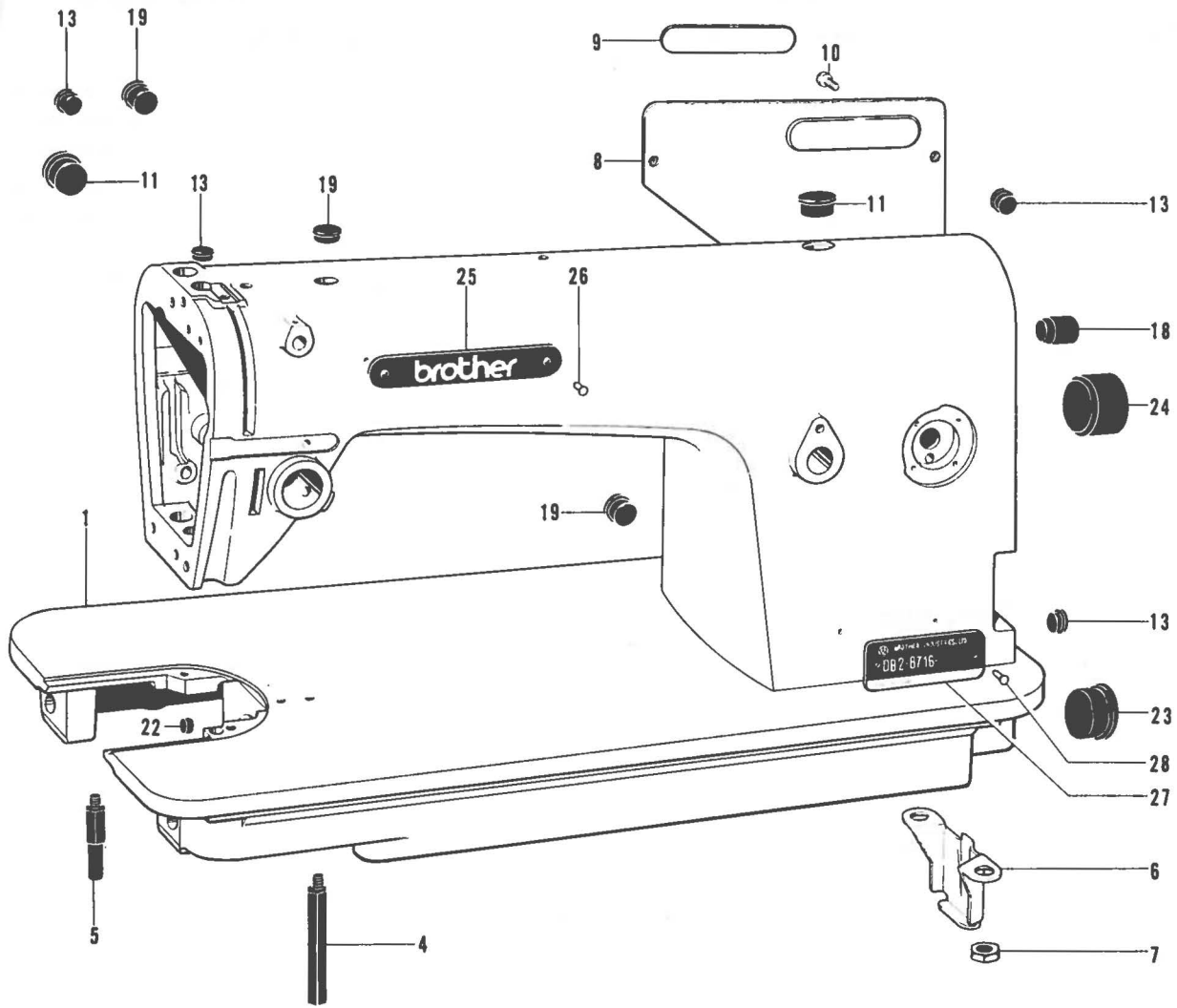

Ref. No.	Name of Parts	Q'ty	Parts No.	Assembly No.	Ref. No.	Name of Parts	Q'ty	Parts No.	Assembly No.
1	Arm Bed	1			18	Oil Cap	1	104832-001	
4	Bed Leg L	1	104829-101		19	Oil Cap	3	104821-001	
5	Bed Leg S	1	104830-101		22	Cap	1	142274-001	
6	Pump Cover	1	145454-001		23	Oil Cap	1	108520-001	
7	Nut 7.14	2	100090-004		24	Oil Cap	1	104451-001	
8	Reae Cover	1	145455-002		25	Name Plate Brother	1		
9	Name Plate	1	156531-001		26	Pin	2		
10	Screw 3.57 x 8	5	062670-812		27	Name Plate	1		
11	Oil Cap	2	104449-001		28	Pin	2		
13	Vinyl Cap	4	104450-001						

B. Threading mechanism/FadenführungsVorrichtung
 Mécanisme de J'enfilage/Mecanismo de la enhebrado

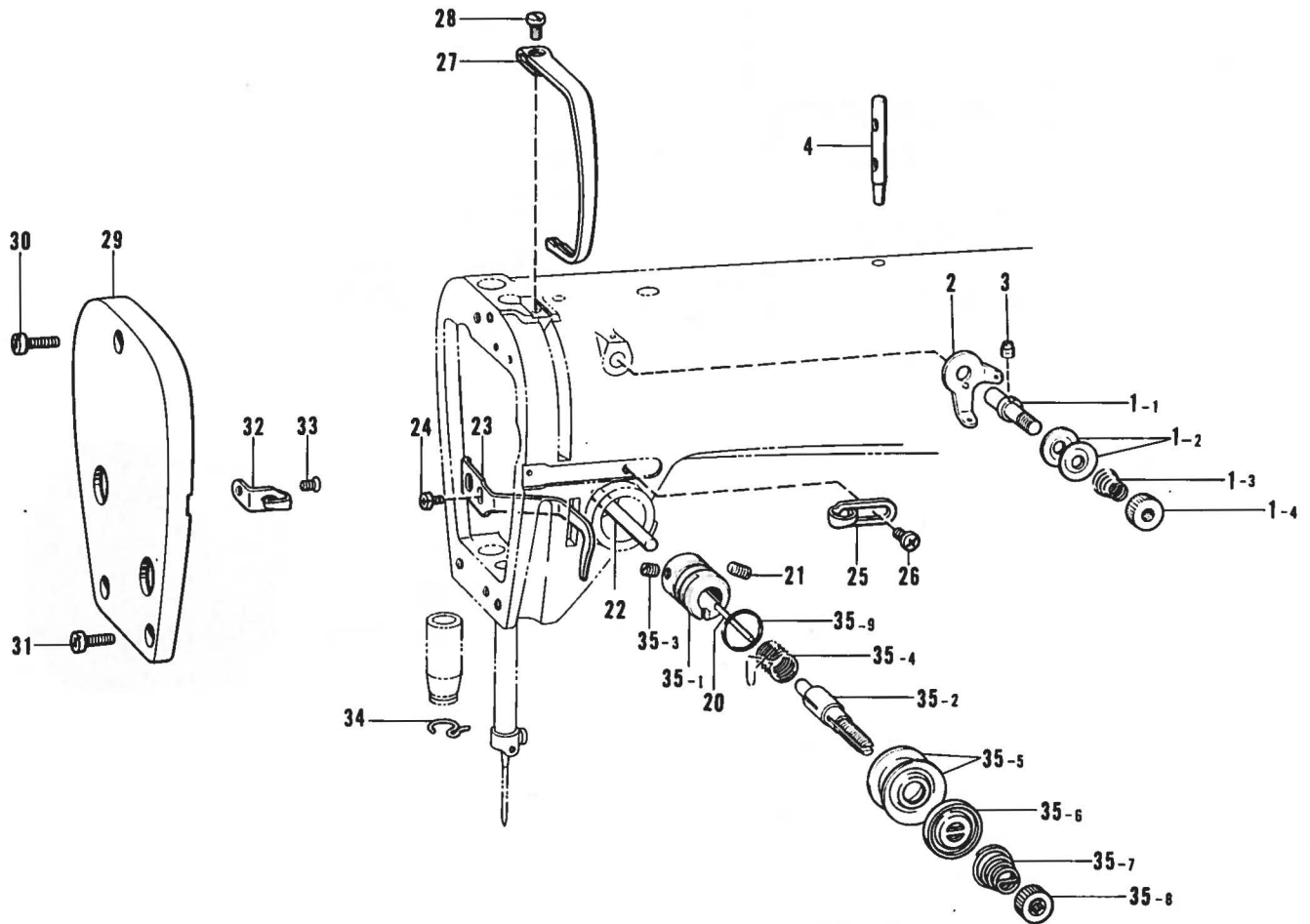

Ref. No.	Name of Parts	Q'ty	Parts No.	Assembly No.	Ref. No.	Name of Parts	Q'ty	Parts No.	Assembly No.
1-1	Pre- Tension Stud	1	154559-001	B-1 Pre Tension Assembly (-1--3) 18,3124-001 (-5) 18,3125-001	29	Face Plate	1	145523-102	
1-2	Thread Guide Disc	2	144504-001		30	Screw 3.57 x 18	1	062671-612	
1-3	Spring (-1--3)	1	154560-001		31	Screw 3.57 x 10	2	062671-012	
	Spring (-5)	1	154562-001		32	Face Plate Thread Guide	1	111476-001	
1-4	Nut	1	155510-001	33	Screw	1	108960-002		
2	Thread Guide	1	154563-001	34	Thread Guide Under	1	100573-001		
3	Screw 4.37	1	151602-002	35-1	Upper Tension Regulator Bracket	1		B-35 Tension Regulator Assembly (-1--3) 183175-001 (-5) 183129-001	
4	Spool Pin	1	147557-101	35-2	Tension Stud	1	100398-001		
20	Tension Release Pin	1	100400-000	35-3	Screw 3.57	1	100402-004		
21	Screw 5.95	1	103950-003	35-4	Thread Take-up Spring (-1--3)	1	104525-001		
22	Tension Release Pin	1	145691-001		Thread Take-up Spring (-5)	1	148924-101		
23	Presser Bar Bracket Thread Guide	1	111469-101	35-5	Tension Disc	2	145446-001		
24	Screw 4.37 x 7	1	062680-712	35-6	Tension Disc Washer	1	159805-001		
25	Thread Guide	1	145522-001	35-7	Spring	1	148924-101		
26	Screw 3.57 x 6	1	062670-612	35-8	Tension Control Nut	1	100136-001		
27	Thread Take-up Cover	1	140885-005	35-9	Packing	1	114294-001		
28	Screw 4.37 x 7	1	062680-712						

C. Needle bar and thread take-up mechanism/Nadelstange und Fadenabnahme vorrichtung
 Mécanisme de la barre à aiguille et releveur de fil/Mecanismo de la barra de aguja y tirahilos

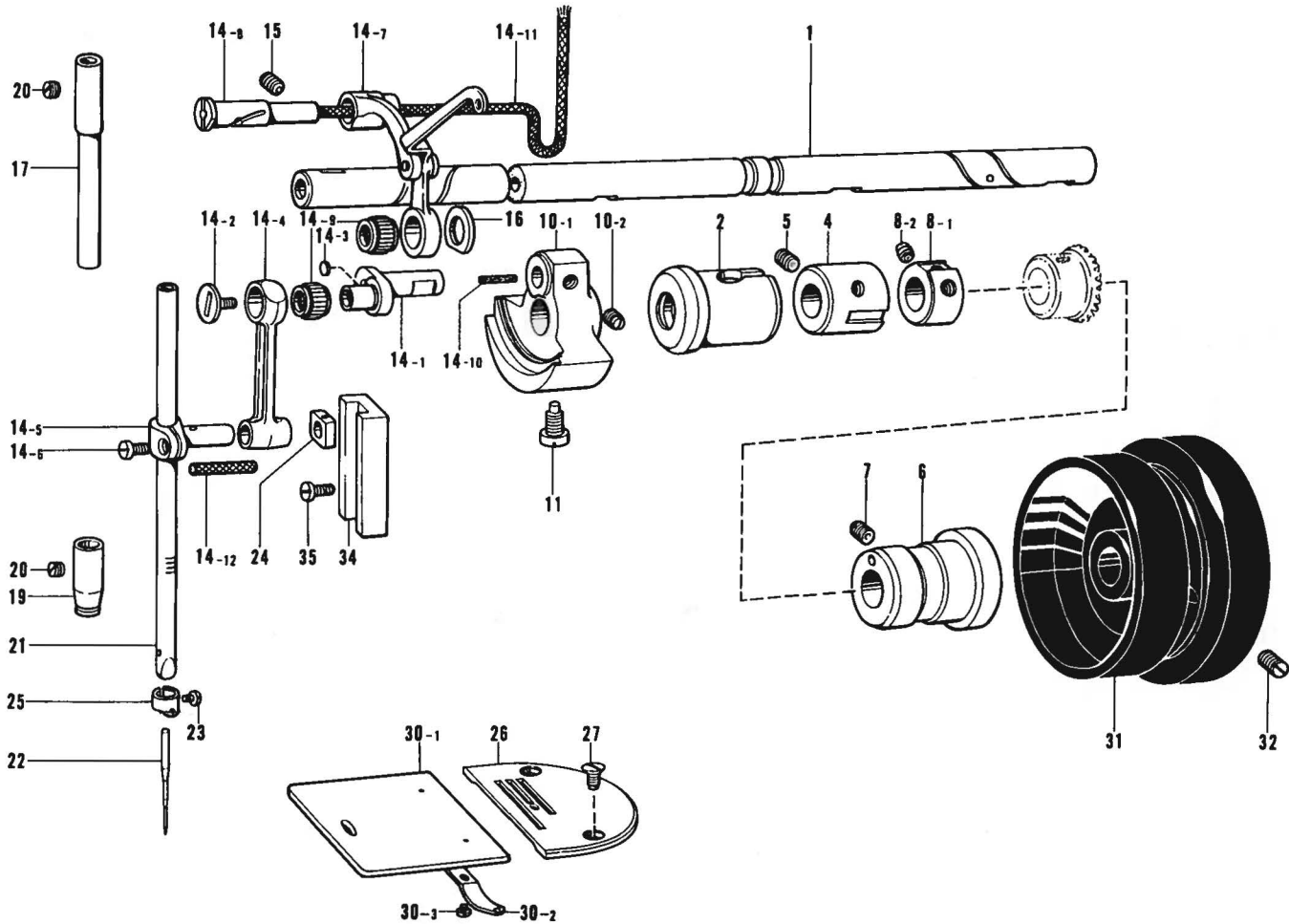

Ref. No.	Name of Parts	Q'ty	Parts No.	Assembly No.	Ref. No.	Name of Parts	Q'ty	Parts No.	Assembly No.
1	Upper Shaft	1	147511-001		17	Needle Bar Bushing Upper	1	111463-001	
2	Upper Shaft Bushing Left	1	145459-101		19	Needle Bar Bushing Lower (-1--3)	1	145468-001	
4	Upper Shaft Bushing Intermediate	1	140726-000			Needle Bar Bushing Lower (-5)	1	142116-001	
5	Screw 5.95 x 6	1	013760-610		20	Screw 5.95	2	100260-001	
6	Upper Shaft Bushing Right	1	145461-101		21	Needle Bar (-1--3)	1	111462-001	
7	Screw 5.95 x 6	1	013760-610			Needle Bar (-3)	1	114908-001	
8-1	Collar	1		C-8 Collar Assembly 181916-001		Needle Bar (-5)	1	145986-001	
8-2	Screw 6.35	2	100251-001			Needle DB x 1 # 14 (-1--3)	1	100265-034	
10-1	Thread Take-up Crank	1		C-10 Thread Take-up Crank (-1--3) 159473-001 (-5) S00909-001	22	Needle DB x 1 # 22 (-5)	1	100265-042	
10-2	Screw 6.35	2	100251-001			Needle DP x 5 # 14 (-1--3)	1	107415-014	
11	Screw 7.14	1	104464-001			Needle DP x 5 # 22 (-5)	1	107415-022	
14-1	Needle Bar Crank	1			23	Screw 3.18	1	140553-102	
14-2	Screw 3.57	1	145465-001		24	Needle Bar Guide Slide Block	1	102630-001	
14-3	Cap	1	145600-000		25	Thread Guide	1	151594-001	
14-4	Tension Disc	1		C-14 Thread Take-up Lever Assembly (-1--3) 147551-101 (-5) 149313-101	26	Needle Plate B18 (-1--3)	1	145971-001	
14-5	Needle Bar Clamp	1				Needle Plate B26 (-5)	1	147245-001	
14-6	Screw 3.57	1	140004-001			Needle Plate AB16	1	156115-001	
14-7	Thread Take-up Supporter Assembly	1			27	Screw 4.37	2	100032-004	
14-8	Stud	1			30-1	Slide Plate	1	100268-004	C-30 Slide Plate Assembly 180018-001
14-9	Bearing	2	147777-000		30-2	Slide Plate Spring	1	114561-001	
14-10	Felt	1	145624-000		30-3	Screw 2.37	2	122771-002	
14-11	Felt	1	118768-001		31	Pulley (Brother)	1	148823-001	
14-12	Felt 4 x 4	1	158727-001			Pulley (EFKA)	1	148822-001	
15	Screw 6.35 x 10	1	013781-012		32	Screw	2	013761-410	
16	Washer	1	110367-001		34	Needle Bar Guide	1	145688-000	
					35	Screw 3.57 x 6	2	062670-612	

D. Rotary hook mechanism/Greifervorrichtung
Mécanisme du crochet rotatif/Mecanismo del cangrejo

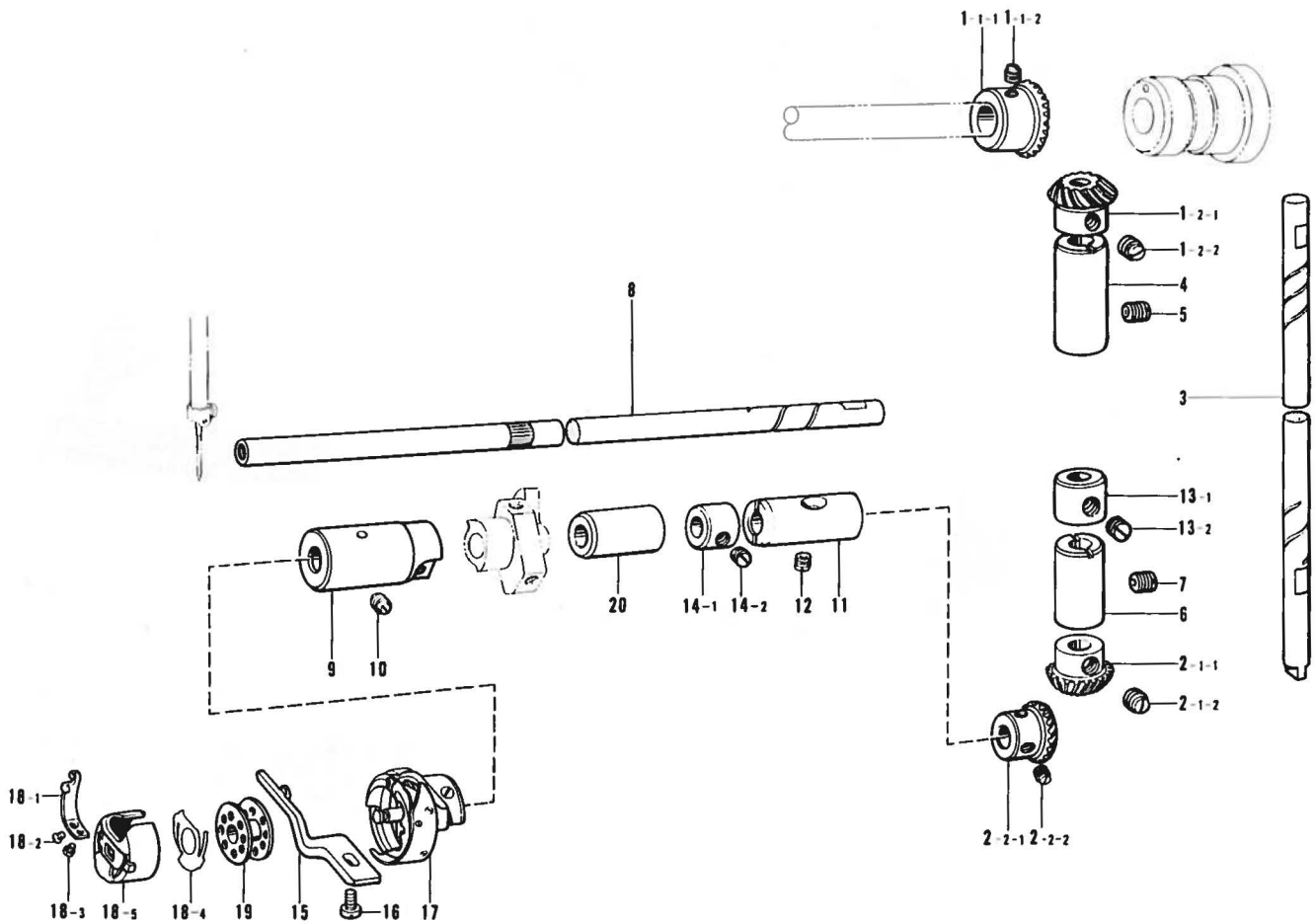

Ref. No.	Name of Parts	Q'ty	Parts No.	Assembly No.	Ref. No.	Name of Parts	Q'ty	Parts No.	Assembly No.
1-1-1	Gear	1		D-1	13-1	Collar	1		Collar Assembly
1-1-2	Screw 6.35	2	100251-001	Bevel Gear	13-2	Screw 6.35	2	101706-001	181995-001
1-2-1	Gear	1		Upper Assembly	14-1	Collar	1		Collar Assembly
1-2-2	Screw 6.35	2	100251-001	140378-001	14-2	Screw 6.35	2	101706-001	181995-001
2-1-1	Gear	1		D-2	15	Bobbin Case holder Position Bracket (-1--3)	1	100367-001	
2-1-2	Screw 6.35	2	100251-001	Bevel Gear		Bobbin Case holder Position Bracket (-5)	1	159324-001	
2-2-1	Gear	1		Lower Assembly	16	Screw 4.37	1	062681-212	
2-2-2	Screw 6.35	2	100251-001	140381-001	17	Rotary hook Assembly (-1--3)	1	153131-001	
3	Vertical Shaft	1	145516-001			Rotary hook Assembly (-5)	1	148846-001	
4	Vertical Shaft Upper Bushing	1	142708-000		18-1	Spring	1	183291-001	D-18
5	Screw 5.95 x 6	1	013760-610		18-2	Screw	1	183292-001	Bobbin Case
6	Vertical Shaft Lower Bushing	1	142709-000		18-3	Screw	1	183293-001	Assembly
7	Screw 5.95	1	013761-410		18-4	Bobbin Tension Spring	1	148967-101	148350-101
8	Lower Shaft	1	154552-001		18-5	Bobbin Case	1		
9	Lower Shaft Bushing Left	1	118761-000		19	Bobbin	1	117132-001	
10	Screw 4.37	1	125925-002		20	Lower Shaft Bushing Middel	1	118762-000	
11	Lower Shaft Bushing Right	1	104520-000						
12	Screw 4.37	1	151607-001						

E. Feed mechanism (1)/Transportvorrichtung (1)
 Mécanisme de l'entraînement (1)/Mecanismo de la alimentación(1)

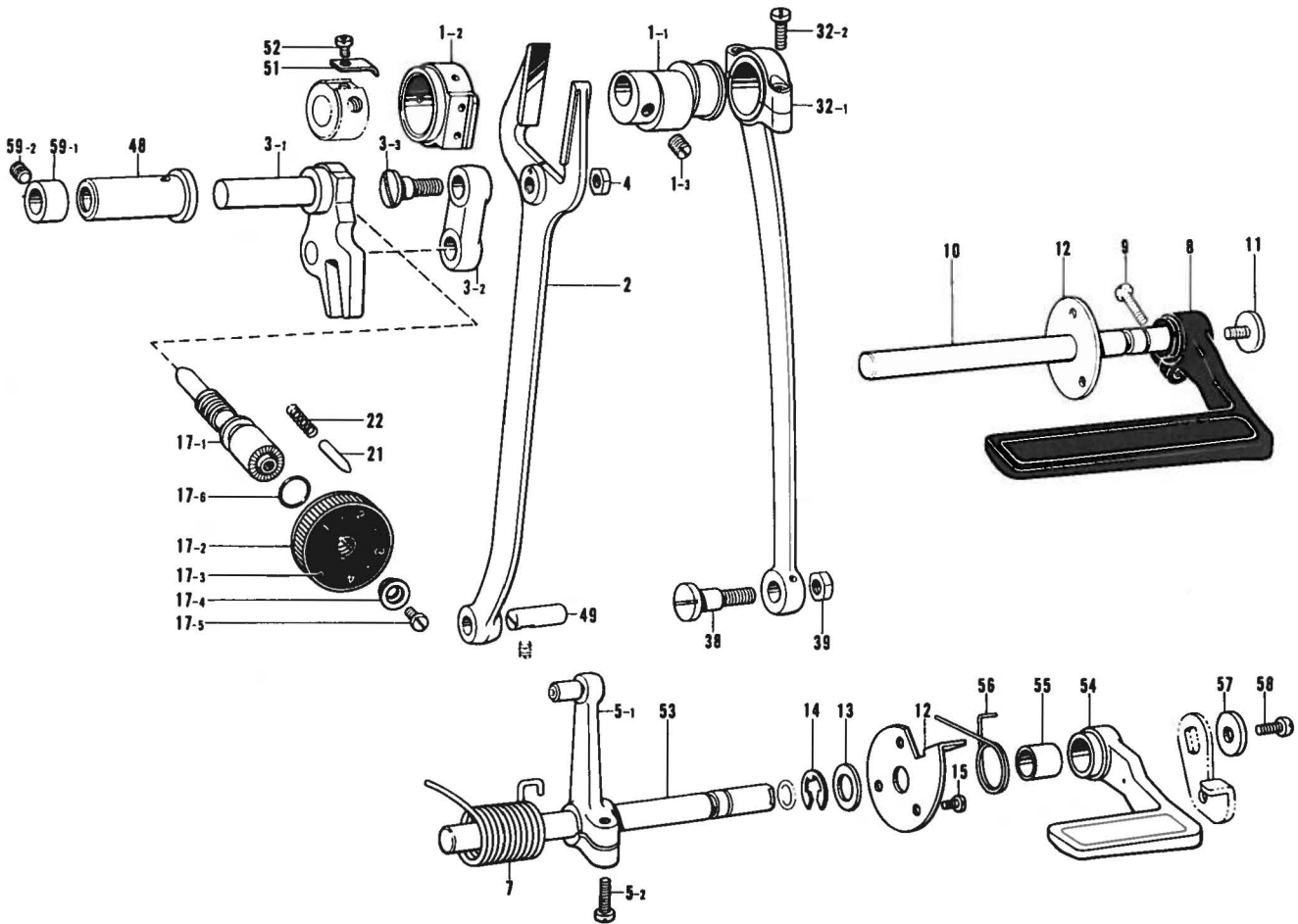

Ref. No.	Name of Parts	Q'ty	Parts No.	Assembly No.	Ref. No.	Name of Parts	Q'ty	Parts No.	Assembly No.
1-1	Feed Cam	1		E-1 Feed Cam Sleeve Assembly (-1) 151063-001 (-3) 147573-001 (-5) 155688-001	17-2	Length Control Dial	1	153168-001	E-17
1-2	Feed Cam Sleeve	1			17-3	Length Control Plate (-1-3)	1	151508-001	Length Control
1-3	Screw 5.95	2	151604-001		17-4	Length Control Plate (-5)	1	151507-001	Assembly
2	Feed Forked Connector	1	109147-001		17-5	Length Control Supporter	1	142746-002	(-1-3)
3-1	Feed Regulator	1		E-3 Feed Regulator Assembly 156634-001	17-6	Screw 4.76	1	142747-002	(-5)
3-2	Feed Link	1			21	Packing	1	108549-001	181482-101
3-3	Screw 7.14	1	145486-001		22	Pin	1	145502-001	
4	Nut 7.14	1	104689-002		32-1	Notch Spring	1	100328-001	
5-1	Feed Regulator Lever	1		E-5 Feed Lever Assembly 181935-001	32-2	Crank Rod	1	107428-003	E-32 Crank Rod Assembly 145506-001
5-2	Screw 4.76 x 14	1	062711-412		38	Screw 4.37	2	107428-003	
7	Spring (-100)	1	150757-001		39	Screw 7.14	1	147509-001	
8	Spring (-400-700)	1	147598-001		48	Nut 7.14	1	104689-002	
9	Reverse Lever (-100)	1	147503-001		49	Feed Regulator Shaft Bushing	1	147500-000	
10	Screw 4.76 x 14 (-100)	1	009711-412		51	Feed Rock Shaft Arm Pin	1	109153-001	
11	Reverse Lever Shaft (-100)	1	147505-001		52	Feed Cam Stopper	1	147764-001	
12	Screw 4.76 (-100)	1	100511-003		53	Screw 3.57 x 4	1	062670-412	
13	Reverse Lever Stopper (-100)	1	147504-001		54	Reverse Lever Shaft (-400-700-900)	1	149085-001	
13	Reverse Lever Stopper (-400-700-900)	1	149083-001		54	Reverse Lever (-400-700-900)	1	149086-001	
14	Washer 10	1	025100-132		55	Collar (-400-700-900)	1	149087-001	
14	Stop Ring	1	048080-342		56	Spring (-400-700-900)	1	149088-001	
15	Screw 3.57 x 5	3	062670-516		57	Washer (-400-700-900)	1	116662-003	
17-1	Length Control Screw	1	109151-101		58	Screw 4.76 x 8 (-400-700-900)	1	062710-812	
					59-1	Collar	1		E-59 Collar Assembly 183178-001
					59-2	Screw 6.35	1	123006-001	

E. Feed mechanism (2)/Transportvorrichtung (2)
 Mécanisme de l'entraînement(2)/Mecanismo de la alimentación (2)

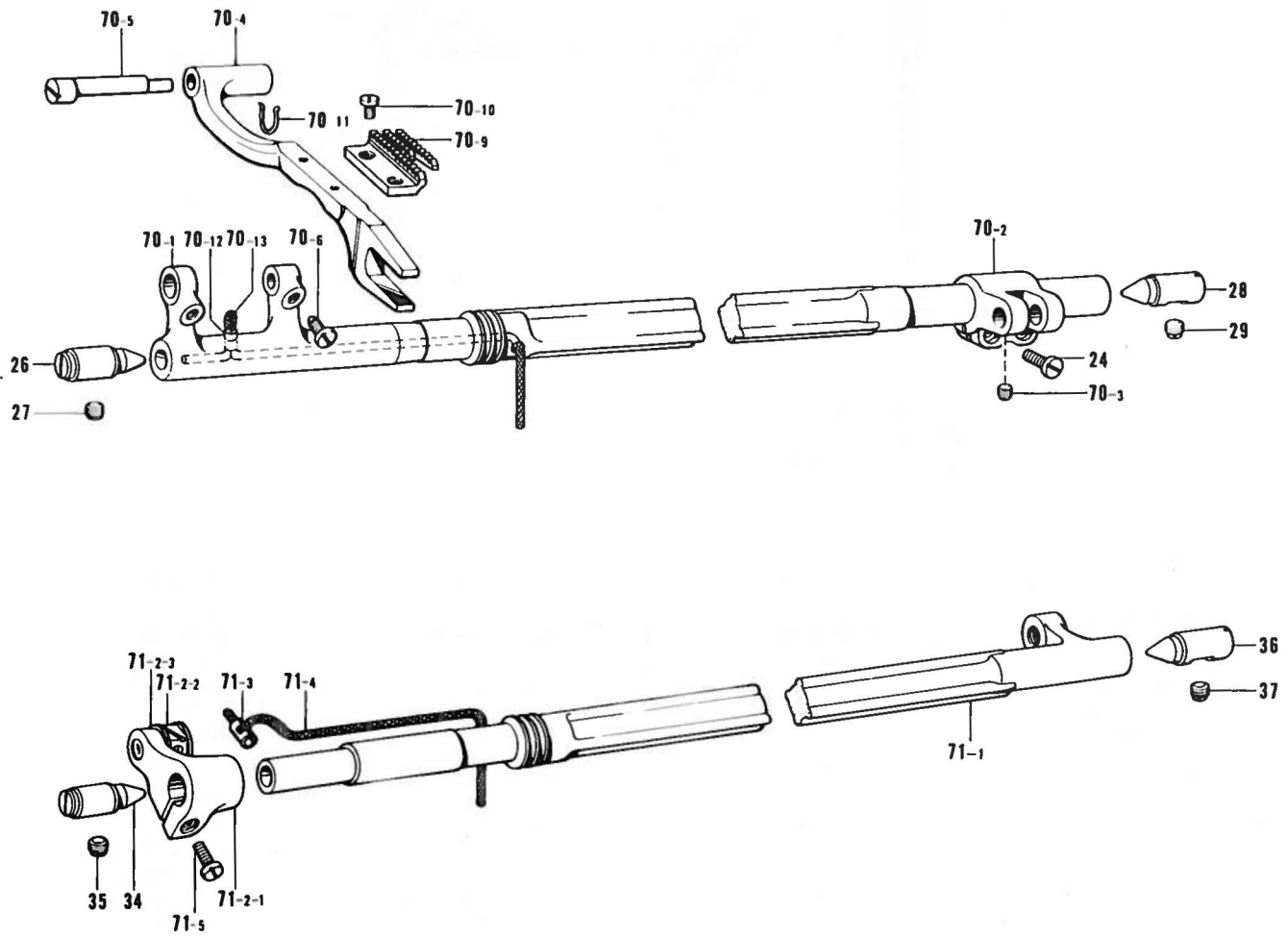

Ref. No.	Name of Parts	Q'ty	Parts No.	Assembly No.	Ref. No.	Name of Parts	Q'ty	Parts No.	Assembly No.
24	Screw 4.37 x 12	2	062681-212			Feed Dog (-1)	1	S01235-001	E-70
26	Taper Center Left	1	104847-001		70- 9	Feed Dog (-3)	1	100334-001	Feed Rock Shaft Assembly
27	Screw 6.35	1	100251-001			Feed Dog (-5)	1	144500-001	(-3) Brother 183196-001
28	Taper Center Right	1	104848-001		70-10	Screw 3.18	2	100080-003	(-5) Brother 183197-001
29	Screw 6.35	1	100251-001		70-11	Wick Hanger	1	150342-001	(-3) EFKA S00214-001
34	Taper Center Left	1	104847-001		70-12	Vinyle Tube	1	150340-000	183311-001(-1)
35	Screw 6.35	1	100251-001		70-13	Wick 4 x 4	1	108801-001	
36	Taper Center Right	1	104848-001		71- 1	Feed Lifting Shaft	1	147510-001	E-71-2
37	Screw 7.14	1	100251-001		71- 2-1	Feed Lifting Arm	1	181941-001	Feed Lifting Arm Assembly
70- 1	Feed Rock Shaft	1		E-70	71- 2-2	Feed Lifting Arm Assembly	1		181941-001
70- 2	Feed Rock Shaft Arm	1	109152-001	E-70 Feed Rock Shaft Assembly	71- 2-3	Washer	1		E-71
70- 3	Screw 4.37	1	151601-002		71- 3	Wick Supporter	1	104567-001	Feed Lifting Shaft Assembly
70- 4	Feed Bar	1	147767-001		71- 4	Wick 4 x 4	1	108802-011	183117-001
70- 5	Feed Bar Shaft	1	156246-001		71- 5	Screw 4.37 x 16	1	009681-612	
70- 6	Screw 4.37	2	120990-001						

F. Pressure foot mechanism/Stoffdrückerfuß
Mécanisme du pied presseur/Mecanismo del prensa telas

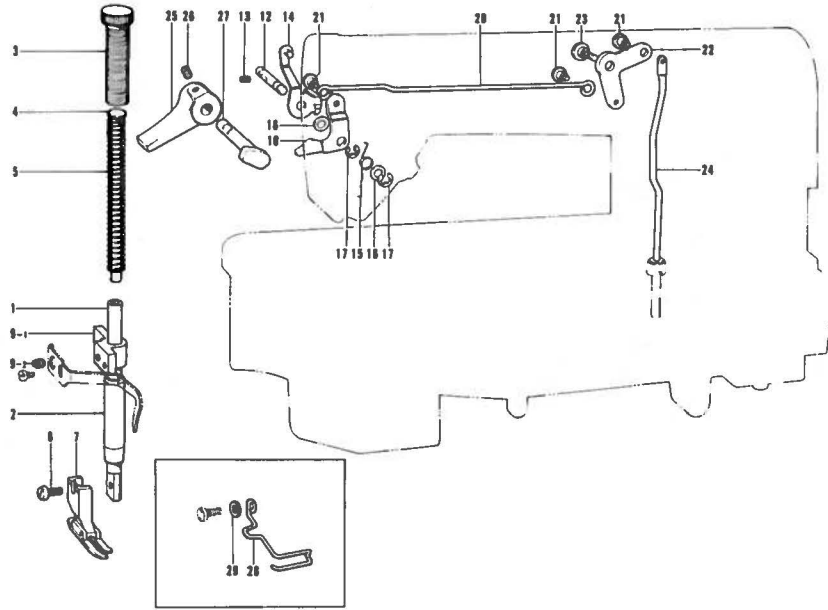

Ref. No.	Name of Parts	Q'ty	Parts No.	Assembly No.	Ref. No.	Name of Parts	Q'ty	Parts No.	Assembly No.
1	Presser Bar	1	111466-001		15	Spring (-100--400)	1	145475-101	
2	Presser Bar Bushing	1	145472-001			Spring (-700--900)	1	147197-101	
3	Screw	1	141207-001		16	Washer	2	109763-002	
4	Presser Spring Bar	1	141208-001		17	Stop Ring	2	048040-342	
5	Presser Spring	1	147514-001		20	Knee Lifter Connector	1	154550-001	
	Presser Foot Assembly (-1--3)	1	153037-101		21	Screw 4.76	3	145478-001	
7	Presser Foot Assembly (-5)	1	145157-001		22	Knee Lifter Lever	1	145479-001	
	Presser Foot Assembly (EFKA)	1	113280-001		23	Screw 6.35	1	145480-001	
8	Screw 40 x 10	1	060671-012		24	Knee Lifter Bar	1	145481-001	
9-1	Presser Bar Clamp	1	S00879-001	F-9 Presser Bar Clamp Assembly 183294-001	25	Presser Bar Lifter	1	145482-001	
9-2	Screw 5.95	1	151604-001		26	Screw 4.76	1	014710-522	
10	Presser Bar Lifter Lever	1	145580-001		27	Presser Bar Lifter Crank (100)	1	145483-001	
12	Presser Bar Lifter Lever Shaft	1	145474-001			Presser Bar Lifter Crank (-400--700--900)	1	156945-101	
13	Fastening Screw	1	100128-002		28	Finger Guard	1	150384-001	
14	Tension Releaser (-100--400)	1	S00839-001		29	Washer 3.5 (-1--3)	1	025350-132	
	Tension Releaser (-700--900)	1	S00841-001			Washer 3.5 (-5)	1	025350-134	

G. Knee lifter mechanism/Kniehebel
Mécanisme de genouillère/Mecanismo de levantador de rodilla

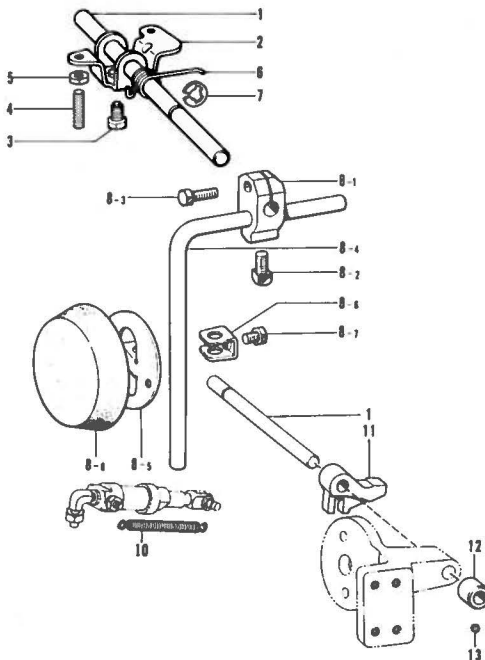

Ref No.	Name of Parts	Q'ty	Parts No.	Assembly No.
1	Knee Lifter Shaft (-300--400)	1	146036-101	
	Knee Lifter Shaft (-900)	1	153127-001	
2	Knee Lifter	1	146037-001	
3	Bolt 5.95	1	146367-001	
4	Screw 5.95	2	104885-001	
5	Nut 5.95	2	100022-004	
6	Spring	1	146038-001	
7	Stop Ring E10	1	146293-001	
8-1	Knee Lifter Joint	1	146039-001	G-8 Knee Lifter Assembly
8-2	Bolt 7.94	1	100463-001	
8-3	Bolt 5.95 x 20	1	017762-013	
8-4	Knee Lifter Bar	1	104619-002	G-8 Knee Lifter Assembly (-100--400) 181427-001
8-5	Knee Lifter Plate	1	114966-001	
8-6	Stopper	1	114967-001	
8-7	Bolt 5.95	1	110087-001	
8-8	Knee Lifter Cover	1	140503-001	
10	Spring (-700)	2	146985-001	
11	Presser foot Lifter (-900)	1	153128-001	
12	Collar (-900)	1	141351-001	
13	Screw 6.35 (-900)	1	101706-003	

H. Lubrication/Schmierung
Lubrification/Lubricacion

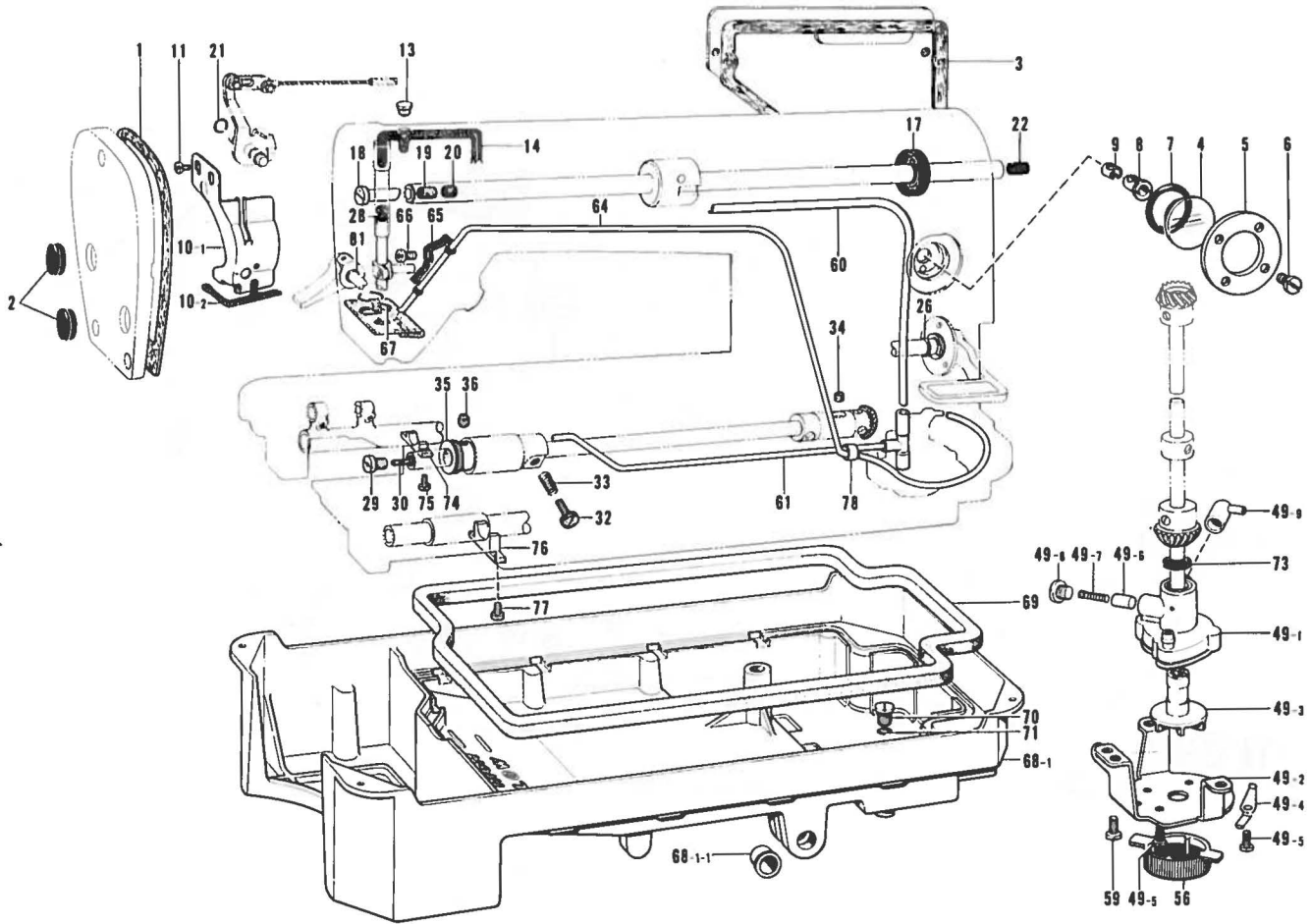

Ref. No.	Name of Parts	Q'ty	Parts No.	Assembly No.	Ref. No.	Name of Parts	Q'ty	Parts No.	Assembly No.
1	Packing	1	145527-000		49- 2	Pump	1	144869-002	Pump Body Assembly 181476-201
2	Oil Cap	2	104449-001		49- 3	Pump Propeller	1	148849-001	
3	Packing	1	145528-000		49- 4	Spring	2	144874-001	
4	Oil Gauge Window	1	104547-001		49- 5	Screw 3.57 x 8	4	062670-812	
5	Oil Gauge Flange	1	151074-001		49- 6	Plunger	1	144875-001	
6	Screw 3.57	4	100257-010		49- 7	Spring	1	144876-001	
7	O Ring	1	081014-670		49- 8	Oil Draining Screw 6.35	1	112467-002	
8	Tube Holder	1	145529-000		49- 9	Joint	1	144878-001	
9	Tube Holder Cap	1	146314-000		56	Pump Filter	1	144872-001	
10-1	Oil Stopper Plate	1		11-10 Oil Stopper Plate Assembly 181639-001	59	Screw 4.37 x 7	3	062680-712	
10-2	Wick 4 x 4	1	109405-001		60	Oil Tube Upper	1	147496-000	
11	Screw 3.57 x 5	2	062670-512		61	Oil Tube D Assembly	1	154555-001	
13	Oil Cap	1	111865-001		64	Tube	1	145543-001	
14	Wick 4 x 4	1	108804-001		65	Tube Holder	1	145547-001	
17	Oil Seal	1	101487-000		66	Screw 3.57 x 5	1	062670-516	
18	Oil Adjustor	1	146333-001		67	Felt Support	1	145737-001	
19	Felt 7 x 10	1	146327-001		68- 1	Oil Pan (100-400)	1	149580-001	
20	Felt	1	107149-001			Oil Pan (700)	1	149581-101	
21	O Ring	1	081001-670		68- 1-1	Bushing	2	149578-000	
22	Rubber Bushing	1	156641-001		69	Packing	1	146040-001	
26	O Ring	1	104564-001		70	Screw 7.94	1	140518-001	
28	Needle Bar Cork	1	111863-001		71	O Ring P7	1	081007-001	
29	Screw	1	109173-001		73	Oil Stopper	1	146196-001	
30	Felt	1	145751-001		74	Oil Stopper	1	118558-001	
32	Screw	1	145534-001		75	Screw 3.57 x 8	2	062670-812	
33	Spring	1	116794-001		76	Oil Stopper	1	118559-001	
34	Felt	1	107155-001		77	Screw 3.57 x 8	2	062670-812	
35	Oil Rejector	1	154554-001		78	Tube	1	146253-000	
36	Screw 4.37	2	102716-001		81	O Ring	1	081001-670	
49- 1	Pump Body	1							

**J. Thread trimmer mechanism/Fadenabschneiderorrichtung
Mécanisme de coupe-fil/Mecanismo de recortadora de orill**

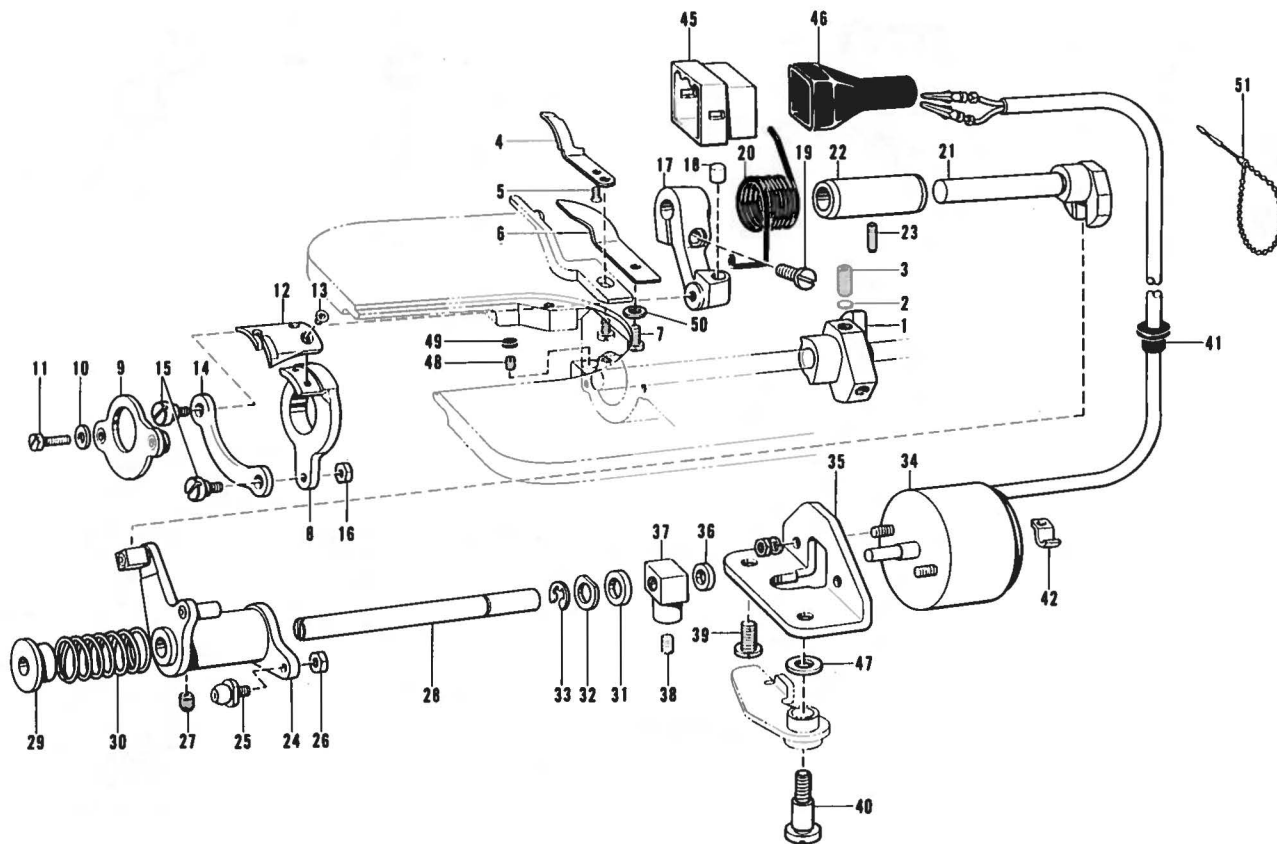

Ref. No.	Name of Parts	Q'ty	Parts No.	Assembly No.	Ref. No.	Name of Parts	Q'ty	Parts No.	Assembly No.
1	Thread Trimmer Clutch	1	154566-001		28	Lever Stud	1	154593-001	
2	Washer 5.3	2	154567-000		29	Collar	1	154594-000	
3	Screw 6.35	2	014771-022		30	Spring	1	154595-001	
4	Fixed Knife	1	154568-001		31	Rubber Stopper	1	154596-000	
5	Screw 3.57	1	102843-004		32	Washer	1	110367-001	
6	Lower Thread Finger	1	154569-001		33	Stop Ring	1	048060-342	
7	Set Screw 4.37 x 7	1	062680-712		34-1	Thread Trimming Solenoid (Brother)	1	154597-001	
8	Movable knife Holder	1	154570-001		34-2	Thread Trimming Solenoid (EFKA)	1	156626-001	
9	Knife Holder Assembly	1	154571-001		35	Solenoid Bracket	1	154598-001	
10	Washer	2	100645-003		36	Stop Ring	1	154599-000	
11	Bolt 4.37	2	154574-001		37	Solenoid Lever	1	154600-001	
12	Movable Knife	1	154575-001		38	Screw 4.37 x 6	1	014680-622	
13	Screw 4.37	2	148537-001		39	Screw 6.35	1	110201-001	
14	Thread Trimming Rod	1	154576-001		40	Screw 6.35	1	155558-001	
15	Stud Screw 4.37	2	151987-001		41	Bushing	1	146080-000	
16	Nut 4.37	1	102571-003		42	Supporter	1	140647-001	
17	Thread Trimming Lever	1	154577-001		45	Nylon Connector 12P (Brother).	1	153969-000	
18	Lever Stopper	1	154578-000			Connector Cap 5 (-400--700--900)	1	153971-001	
19	Screw 4.76 x 14	1	062711-412		46	Connector (-100)	1	153970-001	
20	Trimming Lever Spring	1	154579-001		47	Washer	1	155559-001	
21	Shaft	1	154580-001		48	Screw 3.57 x 7	1	013670-712	
22	Shaft Bushing	1	154581-001		49	Cap	1	155578-000	
23	Screw 4.37	1	151607-001		50	Washer	1	100645-003	
24	Lever Assembly	1	154582-001		51	Bead Band	1	340400-001	
25	Slide Block	1	154590-001						
26	Nut 4.37	1	105234-003						
27	Screw 6.35	1	100251-001						

**K. Tension release mechanism/ Spannungsverminderungsrichtung
Mécánisme de relâche-tension/ Mecanismo de liberador de tensión**

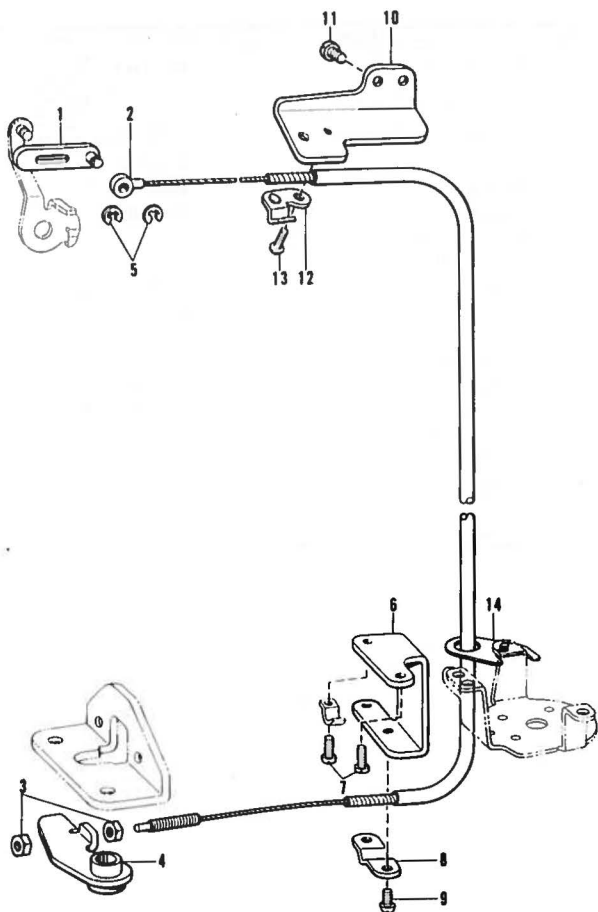

Ref. No.	Name of Parts	Q'ty	Parts No.	Assembly No.
1	Tension Release Lever	1	154601-001	
2	Tension Release Wire	1	154602-001	
3	Nut 4.76	2	110161-004	
4	Tension Release Link Assembly	1	154603-001	
5	Stop Ring E3	2	048030-342	
6	Tension Release Wire Holder D	1	154606-001	
7	Screw 3.57 x 8	2	062670-812	
8	Tension Release Wire Presser D	1	154607-001	
9	Screw 3.57 x 6	2	001670-612	
10	Tension Release Wire Holder U	1	154608-001	
11	Screw 3.57 x 6	2	062670-612	
12	Tension Release Wire Presser U	1	149135-101	
13	Screw 3.57 x 6	1	001670-612	
14	Tension Release Wire Ring	1	155347-001	

**L. Thread wiper mechanism [-400--700--900]/ Fadenspannrichtung [-400--700--900]
Mécánisme de tire-fil [-400--700--900]/ Mecanismo de limpiador de hilos [-400--700--900]**

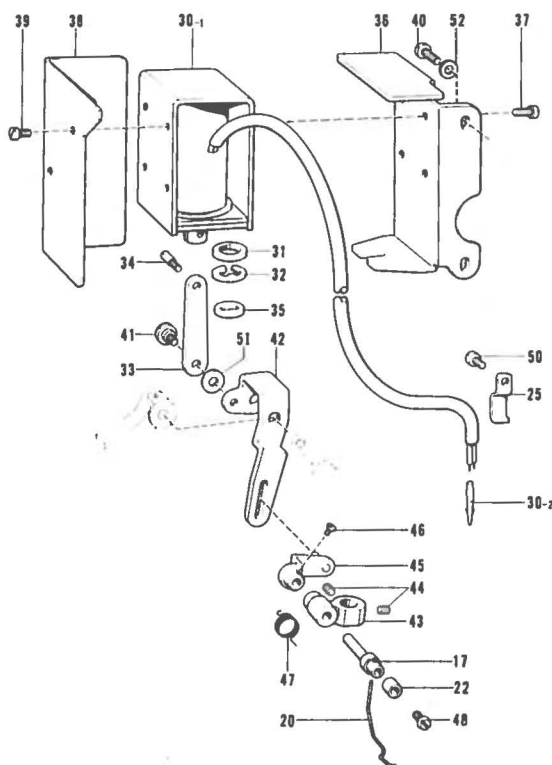

Ref. No.	Name of Parts	Q'ty	Parts No.	Assembly No.
17	Thread Wiper Stud	1	146092-001	
20	Thread Wiper	1	146094-001	
22	Thread Wiper Stud Collar	1	146288-001	
25	Holder L (-400--700--900)	3	142268-001	
30-1	Solenoid	1		Thread Wiper Solenoid Assembly Brother 156988-001 EFK A 158381-001
30-2	Terminal Pin (Brother)	2	143549-001	
31	Plunger Stopper	1	148512-000	
32	Stop Ring E9	1	048090-342	
33	Thread Wiper Link	1	156990-001	
34	Plunger Pin	1	148546-001	
35	Stopper	1	148518-000	
36	Solenoid Bracket	1	156991-001	
37	Screw 3 x 6	4	007300-612	
38	Solenoid Cover	1	156992-001	
39	Screw 3 x 5	2	007300-612	
40	Screw 4.37 x 10	2	062681-012	
41	Stud Screw 4.37	1	113730-001	
42	Thread Wiper Lever	1	156993-001	
43	Thread Wiper Supporter	1	156994-001	
44	Screw 4.37 x 4	2	014680-422	
45	Thread Wiper Crank	1	156995-001	
46	Screw 3.57	1	111443-003	
47	Spring	1	156996-001	
48	Screw 3.57 x 5	1	001670-512	
50	Screw 3.57 x 6	3	062670-612	
51	Washer	1	100645-003	
52	Washer	2	100645-003	

M. Quick reverse switch mechanism [-400--700--900]/Umkehrschalter [-400--700--900]
 Mécanisme de interrupteur de marche arrière rapide [-400--700--900]
 Mecanismo de conmutador de inversion rápida [-400--700--900]

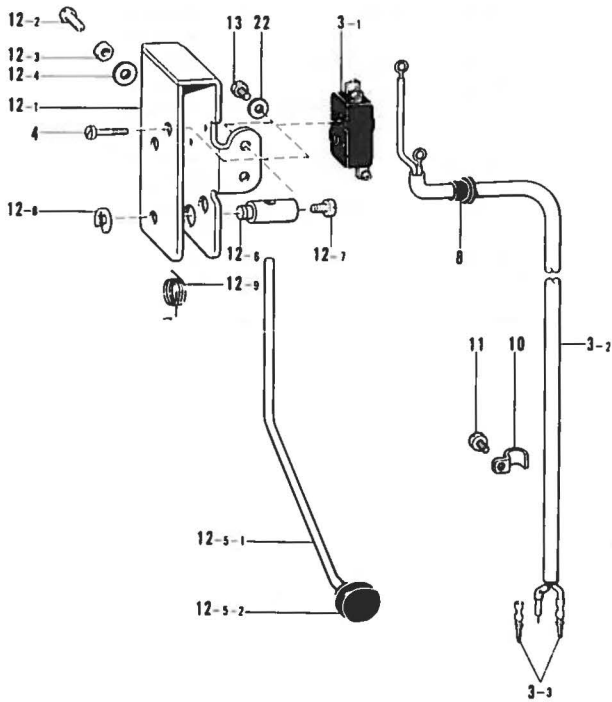

Ref. No.	Name of Parts	Q'ty	Parts No.	Assembly No.
3-1	Micro Switch	1	140643-000	M-3 Reverse Switch Assembly Brother 154206-000 EFKA 151185-001
3-2	Reverse Switch Cord	1		
3-3	Terminal Pin (Brother)	2	143549-000	
4	Screw 2.38	2	146124-001	M-12 Micro Switch Base Assembly
8	Bushing	1	146080-000	
10	Supporter	3	140647-001	
11	Screw 3.57 x 6	3	062677-612	
12-1	Micro Switch Base	1	156997-001	M-12 Micro Switch Base Assembly
12-2	Screw 4.37 x 14	1	062681-412	
12-3	Nut 4.37	1	102571-003	12-5 Actuator Bar Assembly 156999-001
12-4	Washer 4.37	1	025680-232	
12-5-1	Actuator Bar	1		Brother S01277-001
12-5-2	Bottom	1	156479-000	
12-6	Actuator Shaft	1	156998-001	EFKA 151181-001
12-7	Screw 4.37-40 x 10	1	062681-012	
12-8	Stop Ring E4	1	048040-342	
12-9	Spring	1	157999-000	
13	Screw 3.57 x 8	1	062670-812	
22	Washer 3.5	2	025350-332	

N. Quick reverse mechanism [-400--700--900]/Umkehr [-400--700--900]
 Mécanisme de marche arrière rapide [-400--700--900]/Mecanismo de inversión rápida [-400--700--900]

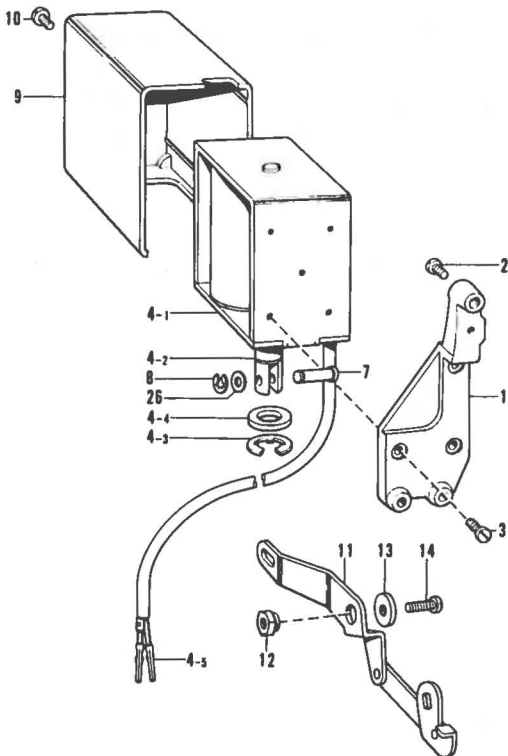

Ref. No.	Name of Parts	Q'ty	Parts No.	Assembly No.
1	Reverse Solenoid Bracket	1	149140-101	N-4 Reverse Solenoid Assembly Brother 154281-001 EFKA 151181-001
2	Screw 6.35 x 18	3	009781-812	
3	Screw 5 x 8	3	007500-812	
4-1	Solenoid	1		
4-2	Plunger	1		
4-3	Stop Ring E12	1	146103-001	
4-4	Stopper	1	146104-000	
4-5	Terminal Pin (Brother)	2	143549-000	
7	Pin	1	153245-001	
8	Stop Ring E4	1	048040-342	
9	Solenoid Cover	1	146105-000	
10	Screw 5 x 6	1	007500-602	
11	Solenoid Lever Assembly	1	149089-001	
12	Solenoid Lever Stud	1	149094-001	
13	Washer	1	149095-001	
14	Screw 6.35 x 18	1	009781-812	
26	Washer	1	153138-001	

**P. Synchronizer / Synchronisator
Synchronisateur / Sincronizador**

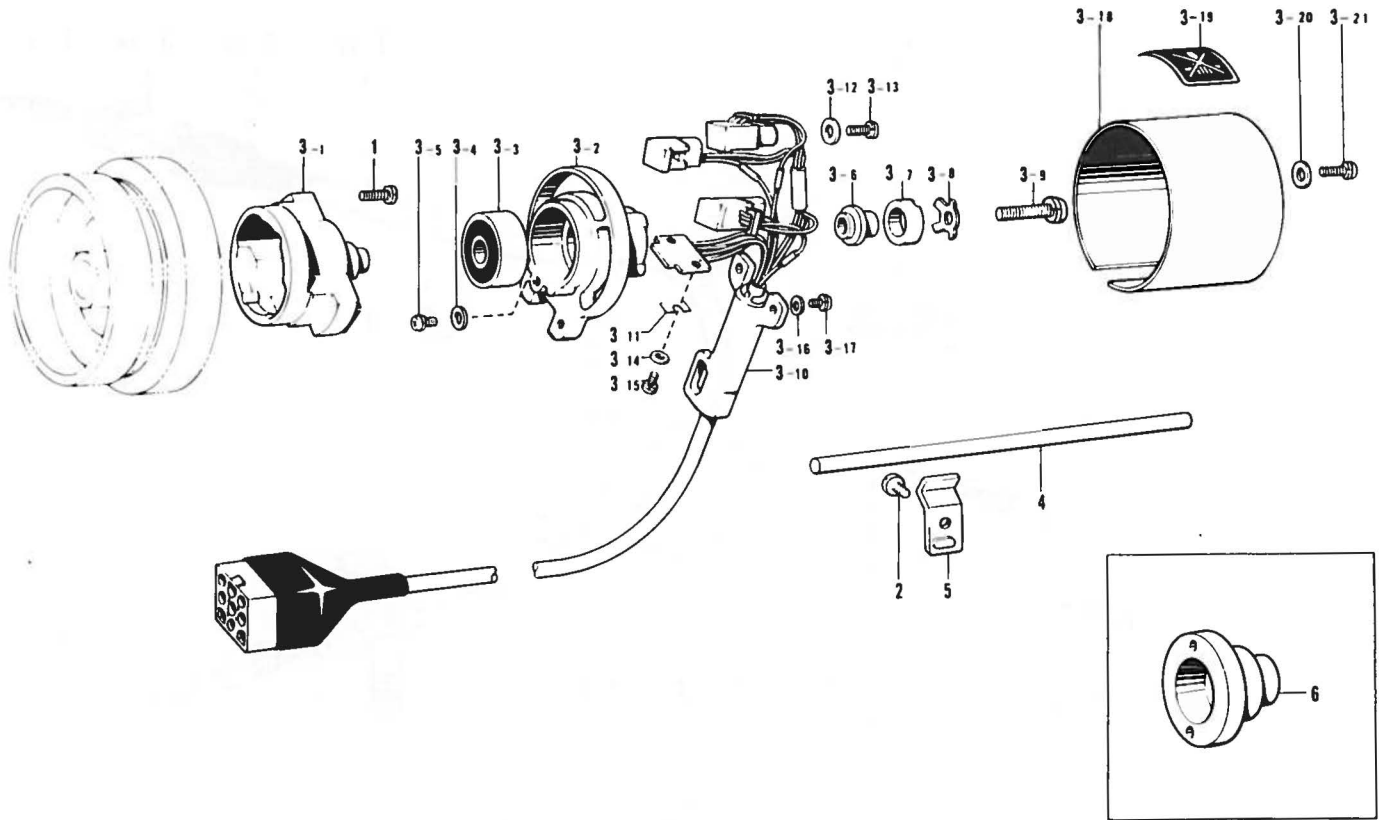

Ref. No.	Name of Parts	Q'ty	Parts No.	Assembly No.	Ref. No.	Name of Parts	Q'ty	Parts No.	Assembly No.
1	Screw 4.76 x 14	2	009711-412		3-12	Washer 4	3	025040-335	
2	Screw 6.35	1	110201-001		3-13	Screw 4 x 12D	3	217093-001	
3- 1	Magnet Stud Assembly	1			3-14	Washer 3	2	025030-135	
3- 2	Hole IC Holder #3	1			3-15	Screw 3 x 6D	2	215083-001	
3- 3	Bearing 6201VV	1			3-16	Washer 4	2	025040-135	
3- 4	Washer 3	1	025030-335	P-3	3-17	Screw 4 x 10D	2	215080-001	
3- 5	Screw 3 x 6D	1	215083-001	Synchronizer	3-18	Synchronizer Cover #3	1		
3- 6	Magnet Setting Bracket	1	219557-000	Assembly #8	3-19	Lavel #3	1		
3- 7	Magnet 12 x 18.7 x 6	1	219558-000	Brother	3-20	Washer 4	2	025040-335	
3- 8	Magnet Holder Plate	1	219559-001	222379-001	3-21	Screw 4 x 10D	2	215080-001	
3- 9	Screw 6 x 25D	1	221421-001		4	Synchronizer Holder Bar #2	1	218944-001	
3-10	Hole IC Code Assembly #4	1			5	Holder	1	216332-001	
3-11	Adjusting Plate	3	219696-000		6	Slip Ring Support (EFKA)	1	148825-001	

Q. Air pressure mechanism [-700]/Luftdruck [-700]
 Mécanisme de la pression d'air [-700] /Mecanismo de la presión rápida [-400-700-900]

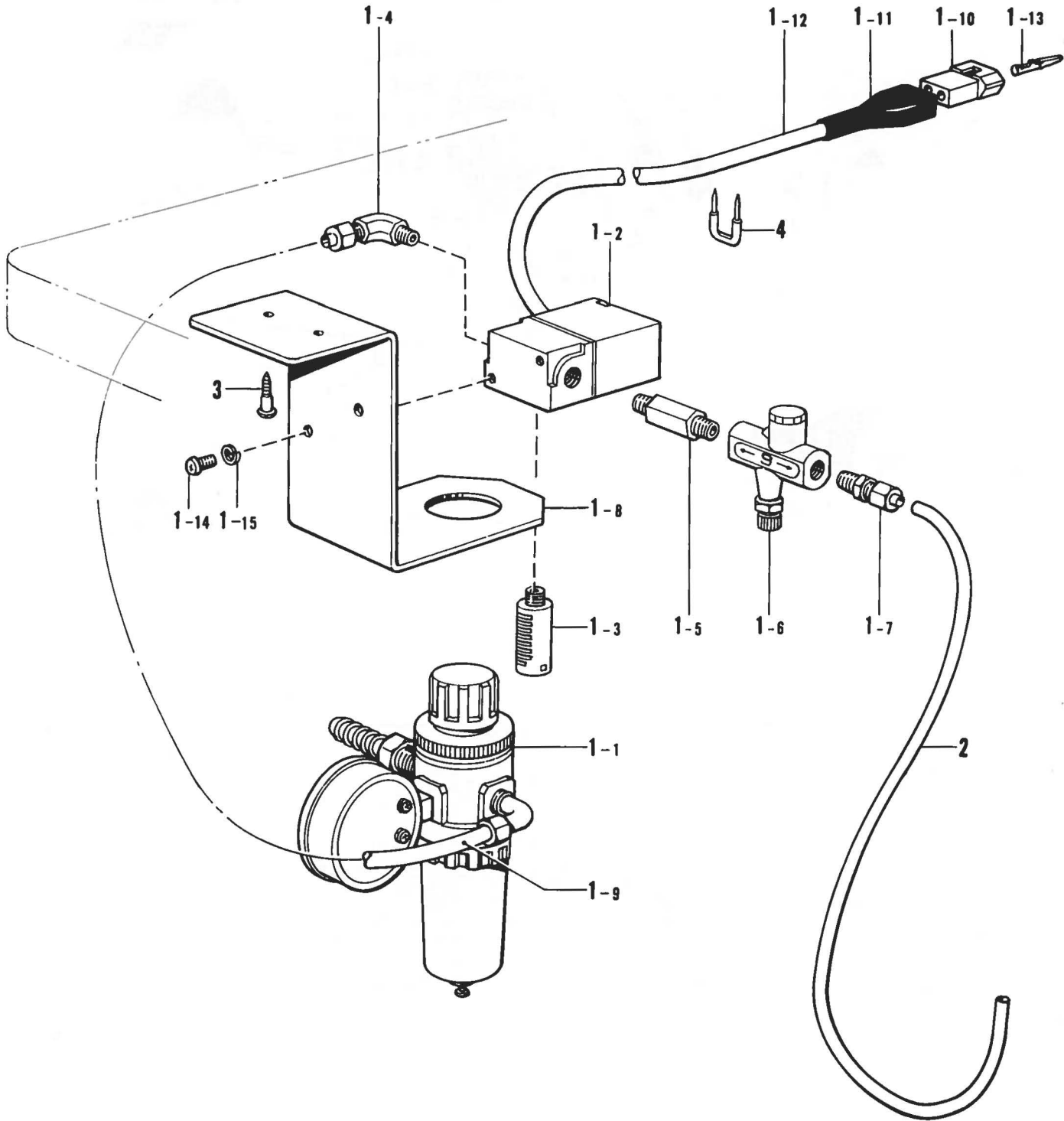

Ref. No.	Name of Parts	Q'ty	Parts No.	Assembly No.	Ref. No.	Name of Parts	Q'ty	Parts No.	Assembly No.
1-1	Air Unit Assembly	1	151153-101	U-1 Air Unit Valve Assembly 151126-101	1-10	Nylon Connector 2P	1	143488-001	U-1 Air Unit Valve Assembly 151126-101
1-2	Air Valve	1	151127-100		1-11	Connector Cap	1	143489-001	
1-3	Silencer	1	140682-001		1-12	Insulator Tube	1	154215-001	
1-4	1/8" Elbow	1	151147-001		1-13	Terminal Pin	2	143549-000	
1-5	Speed Control Connector	1	142037-000		1-14	Screw 5 x 10	2	002501-003	
1-6	Speed Controller	1	142038-001		1-15	Spring Washer 2-5	2	028050-243	
1-7	1/8" Connector	1	140543-000		2	Air Tube	1	151154-000	
1-8	Air Unit Holder Plate	1	154214-001		3	Screw 4.5 x 20	2	101118-001	
1-9	Air Tube	1	140540-000		4	Staple	8	200190-001	

R. Presser foot lifter mechanism [700]/Stoffhalterhebevorrichtung [-700]
 Mécanisme de leueur du pied presseur [-700]/Mecanismo de levantador del prensa telas [-700]

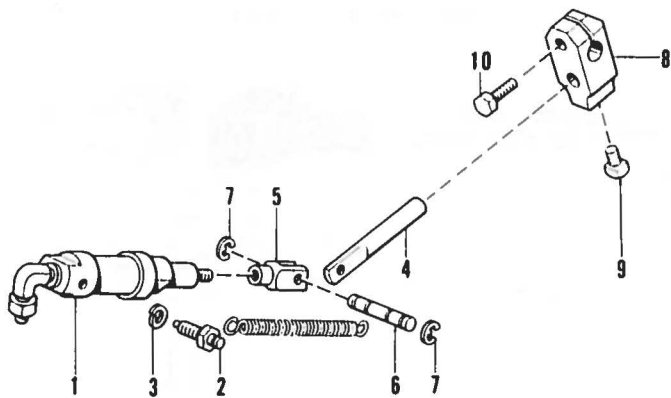

Ref. No.	Name of Parts	Q'ty	Parts No.	Assembly No.
1	Presser Foot Cylinder	1	146157-001	
2	Screw	2	147141-001	
3	Spring Washer 2-6	2	028060-242	
4	Piston Drive Link	1	140668-001	
5	Piston Rod Joint	1	140627-001	
6	Pin	1	146986-001	
7	Stop Ring E4	2	048040-342	
8	Knee Lifter Joint	1	146039-001	
9	Bolt	1	100463-001	
10	Bolt 5.95 x 20	1	017762-013	

R. Presser foot lifter mechanism [-900]/Stoffhalterhebevorrichtung [-900]
 Mécanisme de leueur du pied presseur [-900]/Mecanismo de levantador del prensa telas [-900]

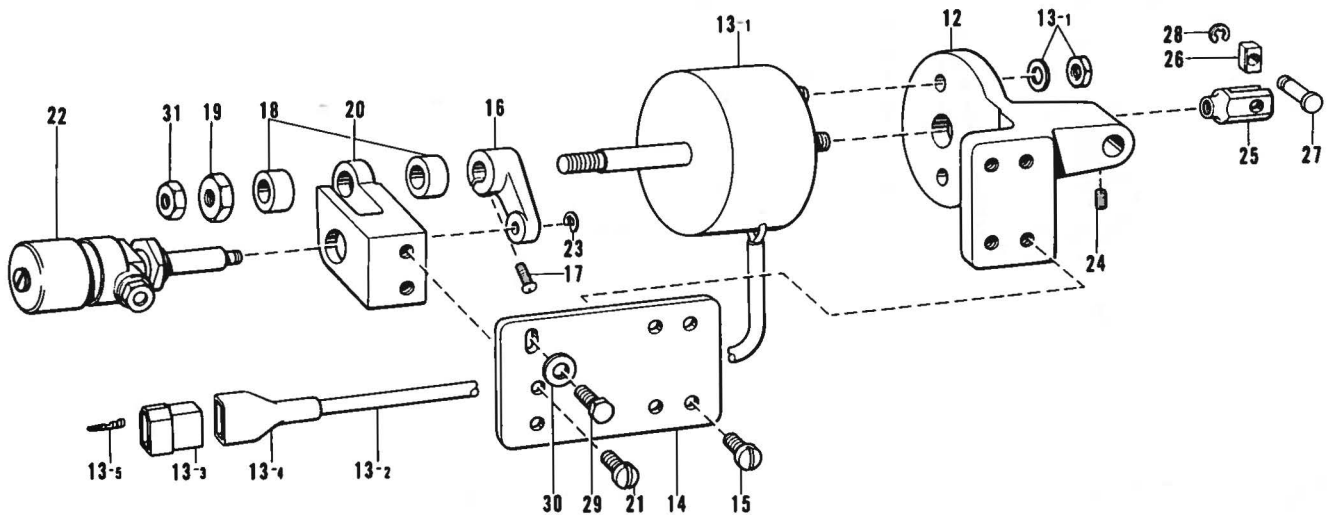

Ref. No.	Name of Parts	Q'ty	Parts No.	Assembly No.	Ref. No.	Name of Parts	Q'ty	Parts No.	Assembly No.
12	Solenoid Bracket	1	153116-000		20	Damper Supportor	1	153123-001	
13-1	Solenoid	1		T-13 Presser Foot Lifting Solenoid Assembly 153117-001	21	Screw 5.95 x 12	2	062761-212	
13-2	Tube	1			22	Damper Assembly	1	153124-001	
13-3	Nylon Connector	1	143484-000		23	Stop Ring E3	1	048030-342	
13-4	Connector Cap	1	143485-001		24	Screw 5.95	1	013760-612	
13-5	Terminal Pin	2	143549-000		25	Piston Rod Joint	1	153198-001	
14	Solenoid Bracket	1	153120-001		26	Needle Bar Guide Slide Block	1	102630-001	
15	Screw 5.95 x 12	4	062761-212		27	Pin	1	153245-001	
16	Damper Lever	1	153121-001		28	Stop Ring E-4	1	048040-342	
17	Screw 5.95 x 14	1	062711-412		29	Bolt 5.95 x 14	1	017761-412	
18	Cussion	2	153122-000		30	Washer 6	1	025060-232	
19	Nut M8	1	158677-001		31	Nut 8	1	021080-302	

S. Knee switch mechanism [-700-900 BROTHER Motor]/Knieschalter [-700-900 BROTHER Motors]
 Mécanisme de interrupteur de genou [-700-900 BROTHER Moteur]
 Mecanismo de conmutador de rodilla [-700-900 BROTHER Motor]

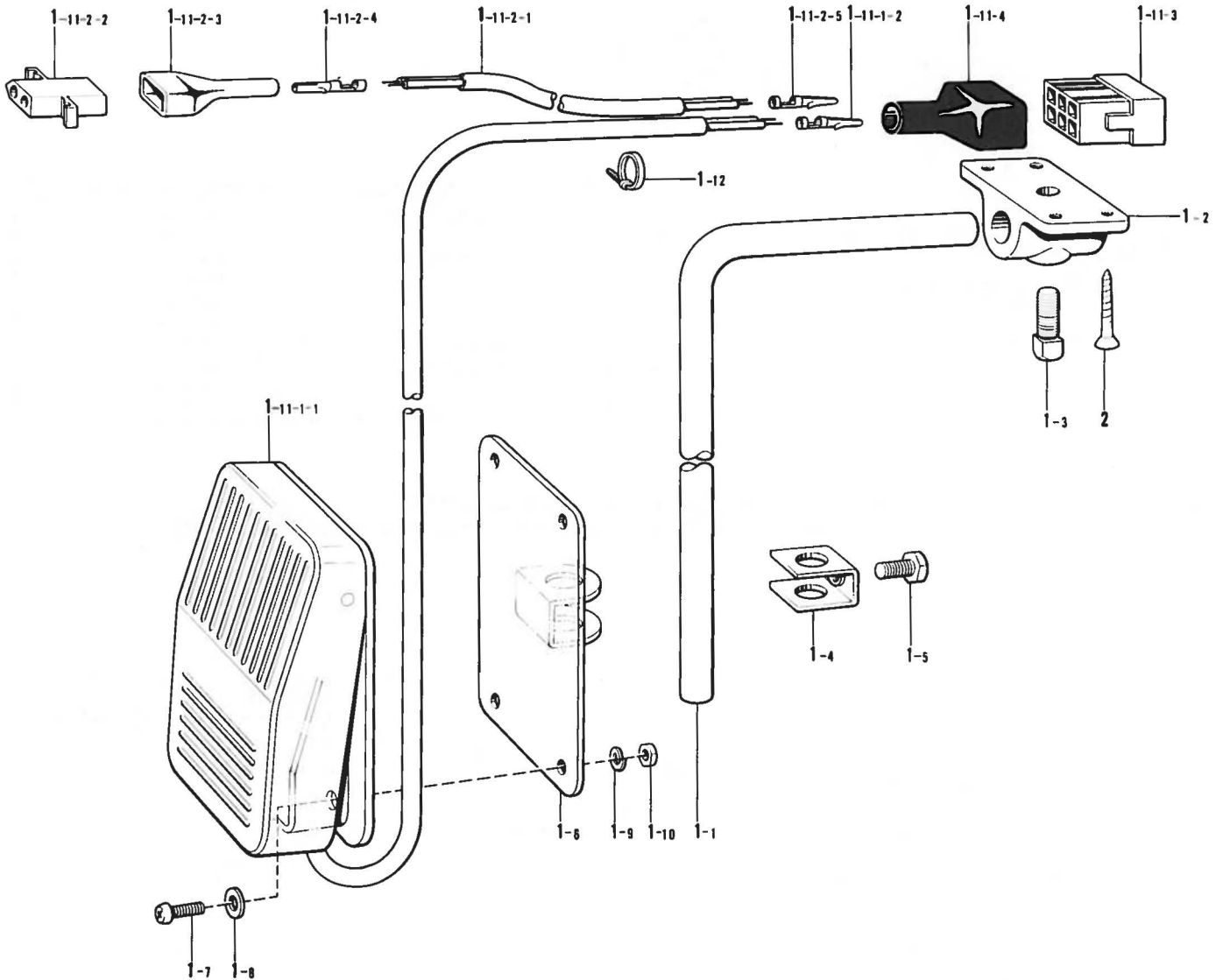

Ref. No.	Name of Parts	Q'ty	Parts No.	Assembly	Ref. No.	Name of Parts	Q'ty	Parts No.	Assembly No.	
1- 1	Knee Switch Shaft	1	142026-003	S-1 Knee Lifter Switch Assembly 154169-001	1-11-1-2	Terminal Pin	2	143549-000	S-1-11-1 Presser Foot Lifter Switch Assembly 154367-000	
1- 2	Knee Lifter Shaft Bracket	1	142027-001		1-11-2-1	Cable	1			S-1-11-2
1- 3	Bolt 7.94	1	100463-001		1-11-2-2	Nylon Connector	1	143499-000		Presser Foot
1- 4	Stopper	1	114967-001		1-11-2-3	Connector Cap	1	143489-001		Lifter Cord
1- 5	Bolt 5.95	1	110087-001		1-11-2-4	Terminal Pin	2	143548-000		Assembly
1- 6	Knee Lifter Switch Plate	1	154170-001		1-11-2-5	Terminal Pin	2	143549-000		154172-001
1- 7	Screw 4 x 10	4	002401-003		1-11-3	Nylon Connector 6P	1	146118-000		S-1-11 Switch Cord Assembly 154368-001
1- 8	Washer 4	4	025040-233		1-11-4	Connector Cap	1	146119-000		S-1 Knee Lifter Switch Assembly 154169-001
1- 9	Washer 2-4	4	028040-243		1-12	Bead Band	1	149799-000		
1-10	Nut 4	4	021400-164		2	Screw 4.1 x 25	4	034422-503		
1-11-1-1	Presser Foot Lifter Switch	1		S-1-11-1 Presser Foot Lifter Switch Assembly 154367-000						

T. Control box mechanism [-900]/Schaltkasten [-900]
 Mécanisme du boîtier de contrôle [-900]/Mecanismo del caja de controles [-900]

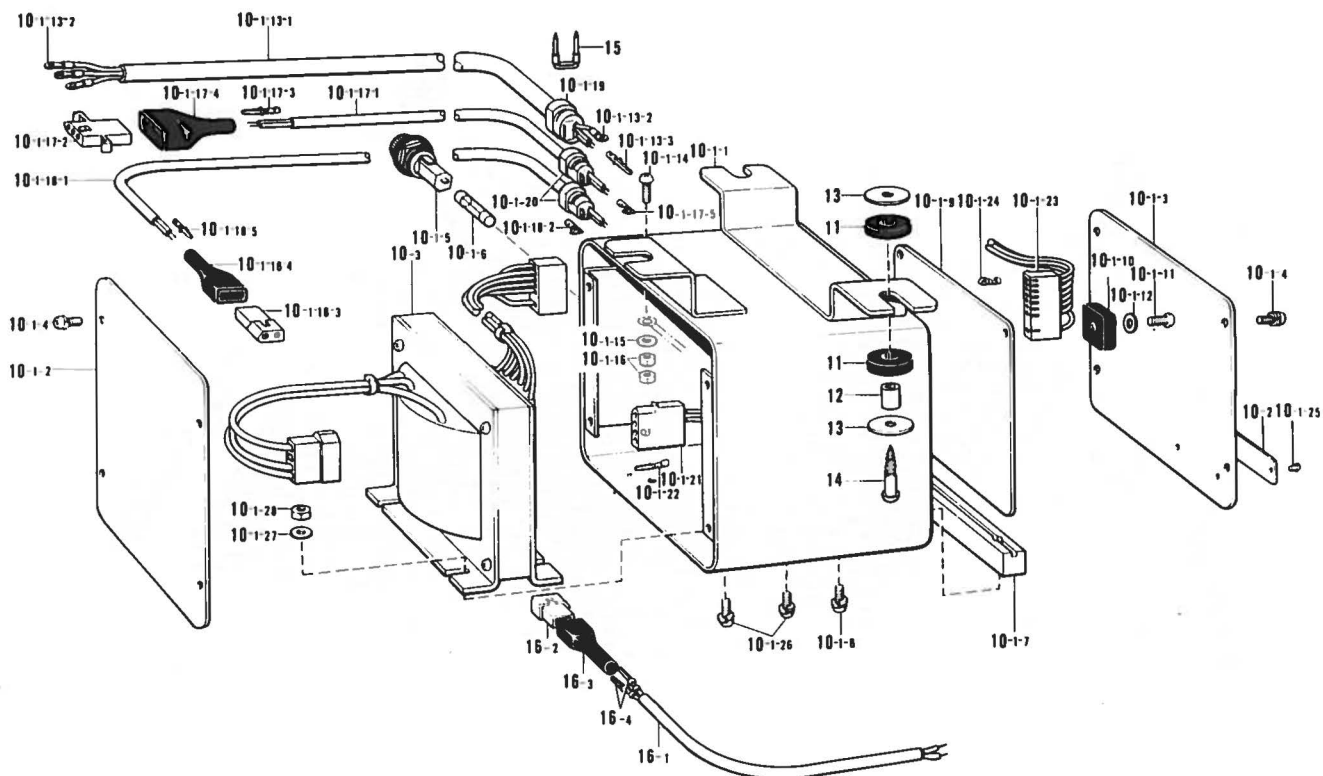

Ref. No.	Name of Parts	Q'ty	Parts No.	Assembly No.	Ref. No.	Name of Parts	Q'ty	Parts No.	Assembly No.
10-1- 1	Box	1		V-10 Solenoid Control Box Assembly 154293-001	10-1-18-3	Nylon Connector	1	143488-000	V-10 Solenoid Control Box Assembly 154293-001
10-1- 2	Front Cover	1			10-1-18-4	Connector Cap	1	143489-001	
10-1- 3	Rear Cover	1			10-1-18-5	Terminal Pin	2	143549-001	
10-1- 4	Screw 4 x 10D	8	215080-001		10-1-19	Bushing #62	1	216365-001	
10-1- 5	Fuse Holder	1	141033-001		10-1-20	Bushing	2	146244-000	
10-1- 6	Fuse (2A)	1	141032-000		10-1-21	Nylon Connector	1	143501-000	
10-1- 7	Circuit Rail	1	153155-000		10-1-22	Terminal Pin	1	143548-000	
10-1- 8	Screw 4 x 10D	2	215080-001		10-1-23	Micro Switch Cord Assembly	1	153165-000	
10-1- 9	Printed Circuit Board	1	153156-001		10-1-24	FL Pin RM 5167	4	219600-001	
10-1-10	Insulation Rubber	2	216351-001		10-1-25	Rivet	2		
10-1-11	Screw 3 x 8	2	002300-805		10-1-26	Screw 4 x 10D	4	215080-001	
10-1-12	Washer 3	2	025030-335		10-1-27	Washer 4	2	025040-233	
10-1-13-1	Cable	1			10-1-28	Nut 4	2	021400-164	
10-1-13-2	Terminal	4			10-2	Name Plate	1		
10-1-13-3	Terminal Pin	1	143548-000	10-3	Transformer 60VA	1	154296-001		
10-1-14	Screw 4 x 12	1	002401-203	11	Rubber Cushion	6	153162-000		
10-1-15	Washer 4	1	025040-233	12	Collar 5.2 x 10 x 11	3	153163-001		
10-1-16	Nut 4	2	021400-164	13	Washer 5.2 x 25	6	153164-001		
10-1-17-1	Cable	1		14	Screw 4.8 x 32	3	031483-203		
10-1-17-2	Nylon Connector	1	143500-000	15	Staple	10	200190-001		
10-1-17-3	Terminal Pin	2	143548-000	16-1	Cable	1			
10-1-17-4	Connector Cap	1	143485-001	16-2	Nylon Connector	1	143499-000		
10-1-17-5	FL Pin RM 5167	2	219600-001	16-3	Connector Cap	1	143489-001		
10-1-18-1	Cable	1		16-4	Terminal Pin	2	143548-000		
10-1-18-2	FL Pin RM 5167	2	219600-001						

U. Treadle mechanism [Option parts] / Pedal [Sonderzubehör]
 Mécanisme de la pédale [Pièces en option] / Mecanismo de la pedal [Piezas opcióna]

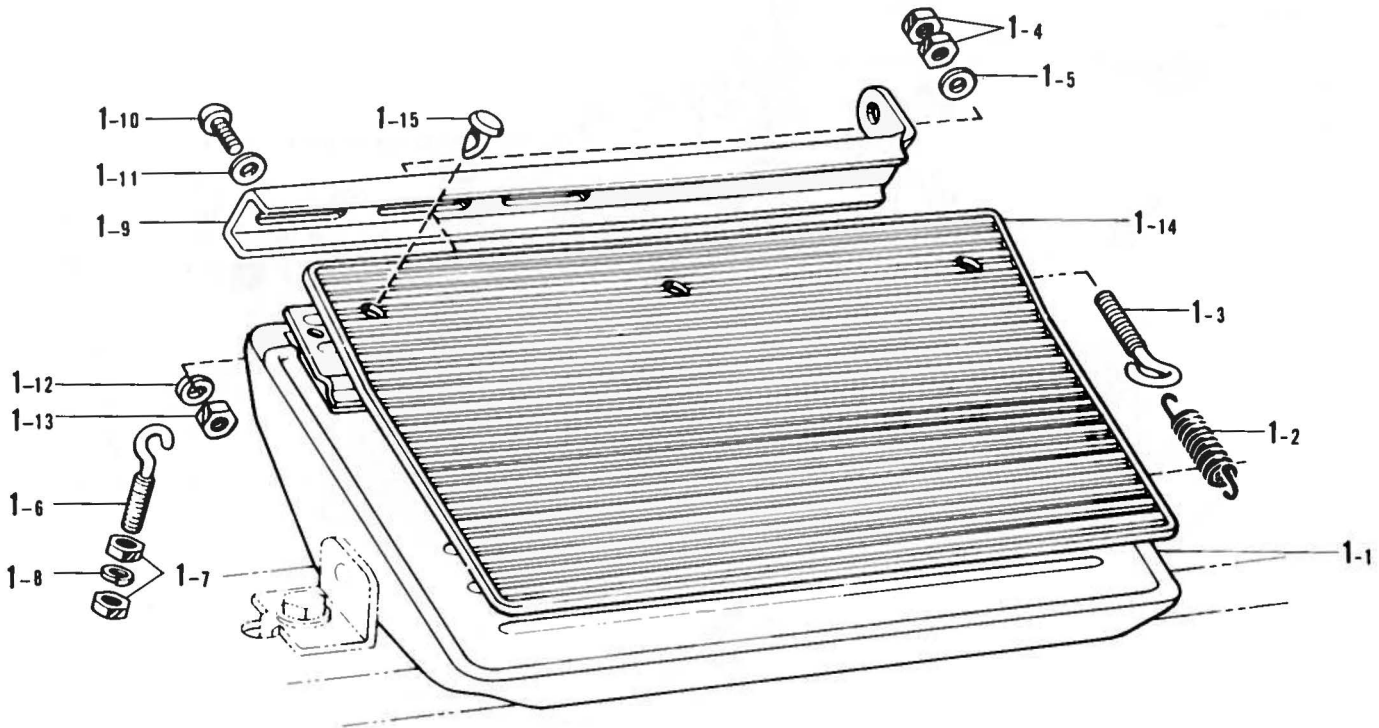

Ref. No.	Name of Parts	Q'ty	Parts No.	Assembly No.	Ref. No.	Name of Parts	Q'ty	Parts No.	Assembly No.
1- 1	Treadle	1		W-1 Treadle Assembly 146175-001	1- 9	Treadle Connector Arm	1		W-1 Treadle Assembly 146175-001
1- 2	Spring	1	146178-001		1-10	Screw 6 x 16	2	001061-606	
1- 3	Spring Hook	1	140953-001		1-11	Washer 6	2	025060-236	
1- 4	Nut 5	2	021500-104		1-12	Spring Washer 2-6	2	028060-242	
1- 5	Washer 5	1	025050-233		1-13	Nut 6	2	021060-206	
1- 6	Adjusting Hook	1	140947-002		1-14	Rubber Cover	1	109268-001	
1- 7	Nut 4 x 5	2	212251-001		1-15	Clip 6	3	146358-001	
1- 8	Washer 2-4	1	028040-243						

V. Bobbin winder mechanism (Option parts)/Spuler (Sonderzubehör)
 Mécanisme du bobineur (Pièces en option)/Mecanismo del devanador de la canilla (Piezas opcióna)

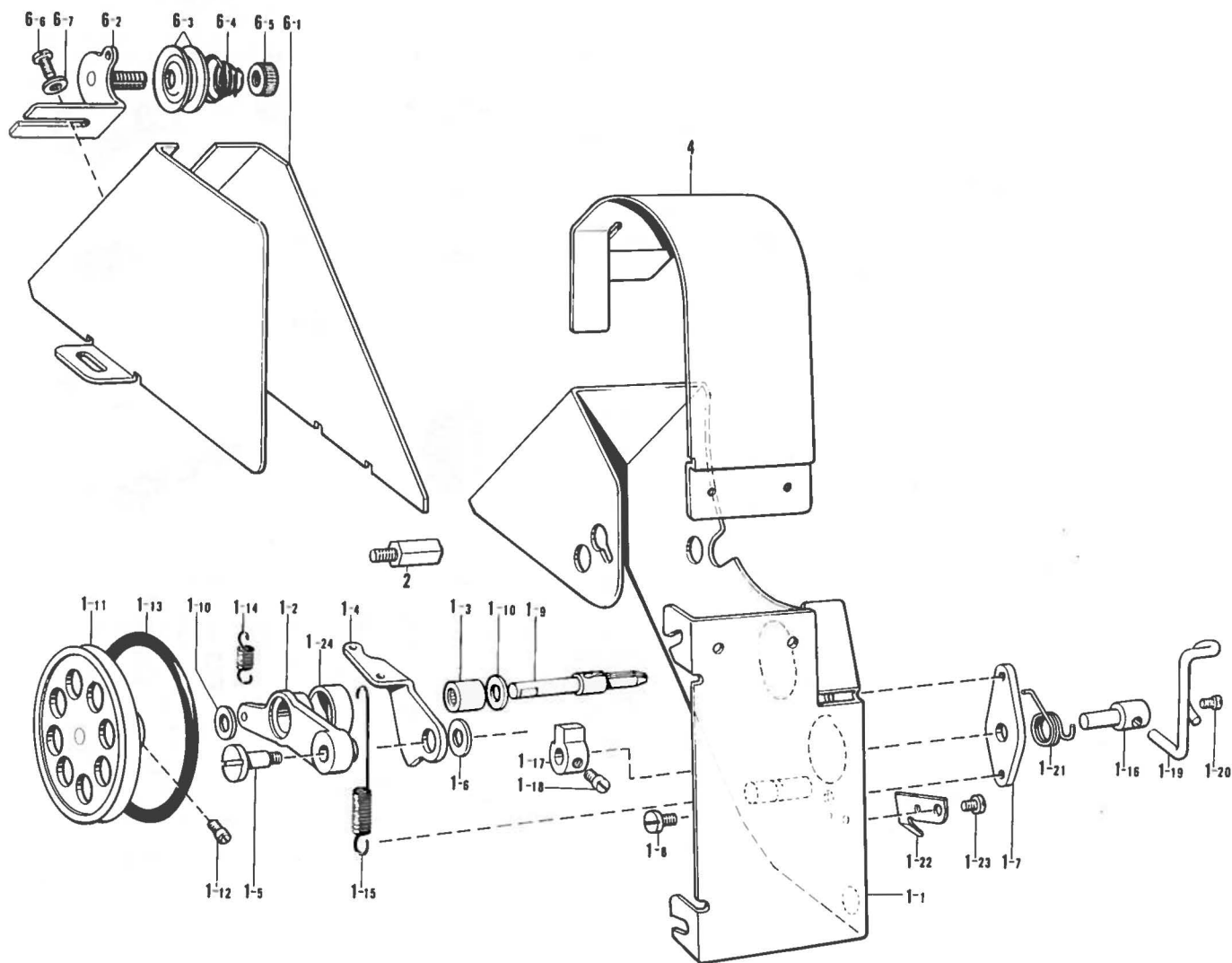

Ref. No.	Name of Parts	Q'ty	Parts No.	Assembly No.	Ref. No.	Name of Parts	Q'ty	Parts No.	Assembly No.
1- 1	Belt Cover	1		V-1 Belt Cover Assembly 157953-001	1-18	Screw 4.37 x 5	2	100366-002	V-1 Belt Cover Assembly 157953-001
1- 2	Bobbin Winder Arm	1	157956-001		1-19	Bobbin Presser	1	157966-001	
1- 3	Needle Bearing	1	147568-001		1-20	Screw 4.37 x 5	1	100366-002	
1- 4	Bobbin Winder Cam Lever	1	157957-001		1-21	Spring	1	157967-001	
1- 5	Screw 4.37	1	157958-001		1-22	Knife	1	157968-001	
1- 6	Washer	1	157986-001		1-23	Screw 4.37 x 4.5	1	009689-412	
1- 7	Bobbin Winder Bracket	1	157959-001		1-24	Oil Seal	1	103738-001	V-6 Belt Cover (D) Assembly 183226-001
1- 8	Screw 4.37 x 4.5	1	009689-412		2	Stud	1	157969-001	
1- 9	Bobbin Winder Shaft	1	157960-001		4	Belt Cover (U)	1	157970-001	
1-10	Washer	2	118735-002		6- 1	Belt Cover (D)	1	157971-001	
1-11	Bobbin Winder Wheel	1	157961-000		6- 2	Bobbin Winder Guide Bracket Assembly	1	145571-101	
1-12	Screw 3.57	2	100128-002		6- 3	Tension Disk	2	145446-001	
1-13	Packing P62	1	081062-090		6- 4	Tension Spring	1	100401-001	
1-14	Spring	1	157962-001		6- 5	Tension Control Nut	1	100136-001	
1-15	Cam Lever Spring	1	157963-001		6- 6	Screw 3.57 x 6	1	001670-612	
1-16	Cam Shaft	1	157964-001		6- 7	Washer 3.5	1	025350-332	
1-17	Bobbin Winder Claw	1	142566-001						

Z. Accessories (1)/Zubehör (1)
Accessories (1)/Accesorios (1)

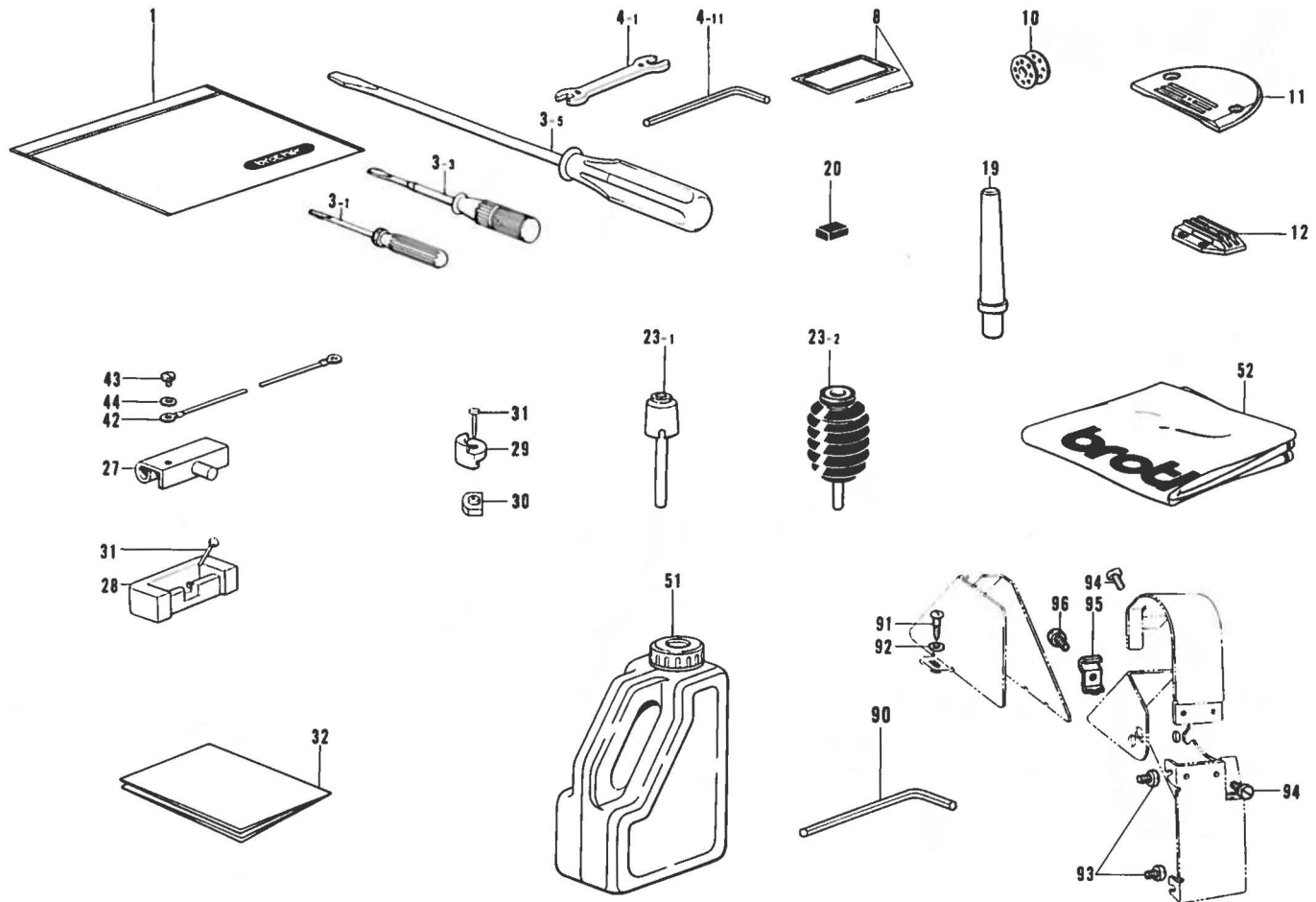

Ref. No.	Name of Parts	Q'ty	Parts No.	Assembly No.	Ref. No.	Name of Parts	Q'ty	Parts No.	Assembly No.
1	Vinyl Bag	1	I22991-001		27	Rubber Assembly	2	145945-001	
3- 1	Screw Driver 1.9 x 52	1	I42443-001		28	Rubber Hinge	2	143910-001	
3- 3	Screw Driver 3.4 x 70	1	I18837-001		29	Head Cushion	4	146003-101	
3- 5	Screw Driver 5.5 x 190	1	I01572-101		30	Oil Pan Cushion	4	146004-001	
4- 1	Spanner 8 x 9	1	I00887-001		31	Nail	4	I09714-000	
4-11	Spanner 2	1	I46049-001		32	Table Sheet	4	I44615-001	
8	Needle DB x 1 # 22 (4 Set)	1	I00265-442		42	Earth Wire	1	I45946-001	
	Needle DB x 1 # 14 (4 Set)	1	I00265-434		43	Screw 4.37 x 6	1	062680-616	
	Needle DP x 5 # 14 (4 Set)	1	I07415-414		44	Washer 4.37	1	025680-133	
	Needle DP x 5 # 22 (4 Set)	1	I07415-422		51	Oil Tank	1	I54702-001	
10	Bobbin	4	I17132-001		52	Head Cover	1	I44222-001	
11	Needle Plate AB18 (-1--3)	1	I56116-001		90	Spanner 3	1	I42721-001	
	Needle Plate H26 (-5)	1	I50792-001		91	Screw 5.5 x 20	2	I00666-002	
12	Feed dog (-1--3)	1	I56113-001		92	Washer 5.56	2	025750-132	
	Feed dog (-5)	1	I50792-001		93	Screw 5.95 x 8	2	062760-812	
19	Head Rest	1	I00477-001		94	Screw 3.57	3	I00257-010	
20	Magnet	2	I12525-000		95	Cord Stopper	1	I45597-001	
23-1	Knee Lifter Complying Bar (-100-400)	1	I45573-000		96	Screw 4.37 x 8	1	062760-812	
23-2	Knee Lifter Complying Bar Assembly (-700-900)	1	S00096-001						

Z. Accessories (2) [Option parts]/Zubehör (2)
 Accessoires (2) [Pièces en option]/Accesorios (2) [Piezas opeióna]

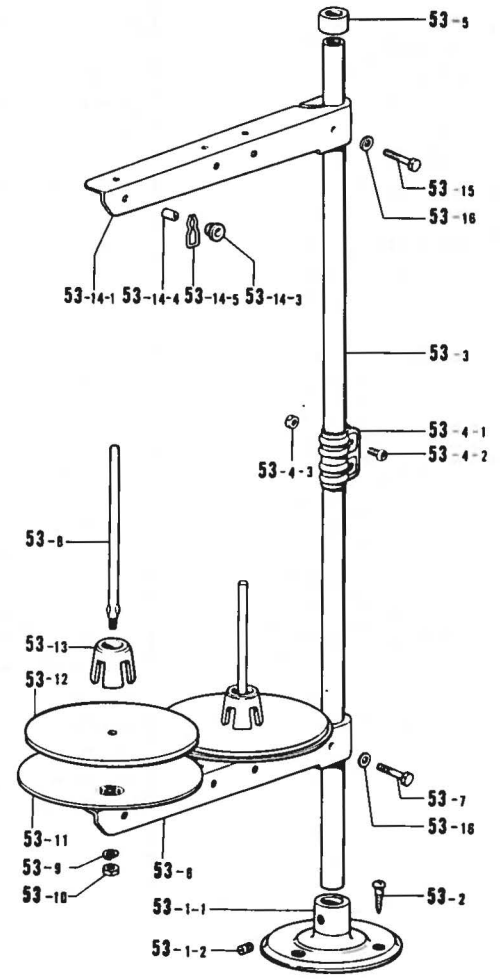
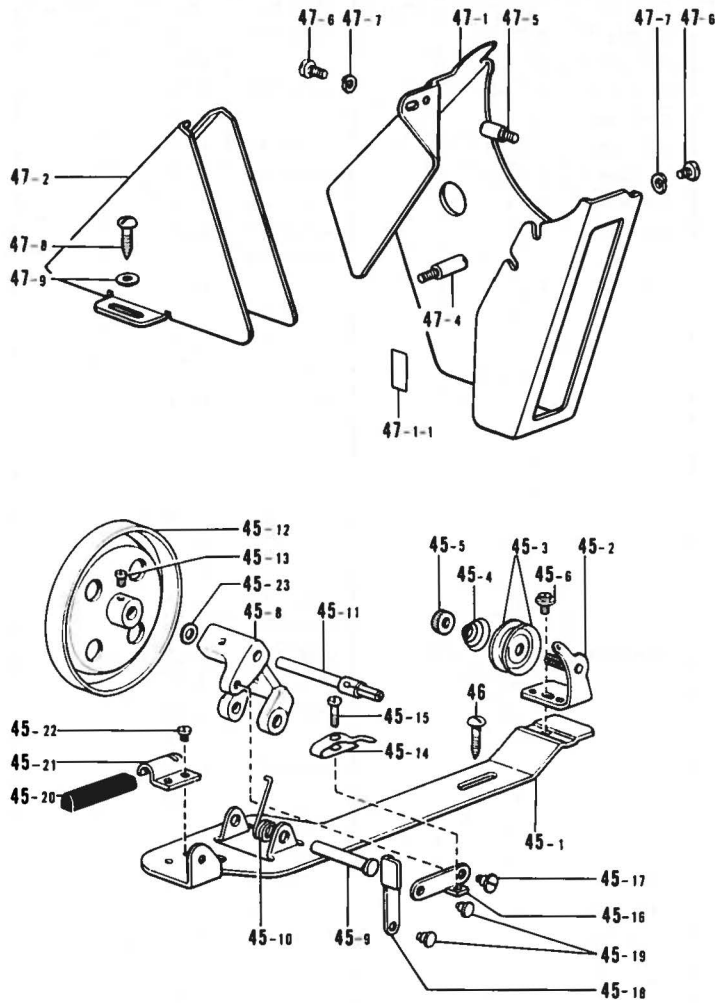

Ref. No.	Name of Parts	Q'ty	Parts No.	Assembly No.	Ref. No.	Name of Parts	Q'ty	Parts No.	Assembly No.	
45- 1	Bobbin Winder Wheel Bracket	1		Z-45 Bobbin Winder Assembly 117963-001	47- 5	Stud (B)	1	147856-001	Z-47 Belt Cover Complete 147899-011	
45- 2	Bobbin Winder Guide Assembly	1			47- 6	Screw 4.37 x 8	2	009680-812		
45- 3	Tension Disc	2	145446-001		47- 7	Spring Washer 2-4.37	2	028680-242		
45- 4	Tension Spring	1	100401-001		47- 8	Screw 5.5 x 20	2	100666-002		
45- 5	Tension Control Nut	1			47- 9	Washer 5.56	2	025750-132		
45- 6	Screw 4.37	1			53- 1-1	Cotton Stand Base	1	150189-001		Z-53-1 Cotton Stand Base Assembly 150139-001
45- 8	Bobbin Winder Wheel Shaft Supporter	1			53- 1-2	Screw 6 x 7	2	150181-101		Z-53 Cotton Stand Assembly 147899-011
45- 9	Pin	1			53- 2	Screw 4.5 x 22	3	031452-203		
45-10	Spring	1	117969-001		53- 3	Pipe	2	150172-001		
45-11	Bobbin Winder Shaft	1	117970-001		53- 4-1	Joint	1		Z-53-4 Joint for Cotton Stand 150106-001	
45-12	Bobbin Winder Wheel Assembly	1			53- 4-2	Screw 5 x 14	2	150202-001	Z-53 Cotton Stand Assembly 150150-003	
45-13	Screw 4.37 x 5	1	100366-002		53- 4-3	Nut 5	2	021500-103		
45-14	Bobbin Presser	1	100656-001		53- 5	Cap	1			
45-15	Screw 3.18	1	100657-001		53- 6	Spool Holder 2	1	150178-001		
45-16	Bobbin Presser Arm	1			53- 7	Bolt 5 x 28	1	017502-803		
45-17	Stud Screw 3.18	1	100659-001		53- 8	Spool Shaft (B)	2	150179-001		
45-18	Bobbin Presser Bracket	1			53- 9	Spring Washer 2-5	2	028050-243		
45-19	Pin	2			53-10	Nut 5	2	021500-103		
45-20	Bobbin Winder Wheel Stopper	1	100662-001		53-11	Spool Stand Base	2	150180-000		
45-21	Bobbin Winder Wheel Stopper Holder	1			53-12	Spool Mat	2	150182-000		
45-22	Screw 3.57 x 3.5	1	009679-312		53-13	Spool Cushion	2	126863-000		
45-23	Washer	2			53-14-1	Spool Holder 2	1		Z-53-14 Thread hanger Assembly 2	
46	Screw 5.5 x 20	2	100666-002		53-14-3	Thread Hanger	2		Z-53 Cotton Stand Assembly 150192-003	
47- 1	Belt Cover (UE)	1	147853-001	53-14-4	Thread Bushing	2	142990-001			
47- 1-1	Cushion 7 x 12	1	146289-001	53-14-5	Thread Guide Spring	2	150184-001			
47- 2	Belt Cover (D)	1	147854-001	53-15	Bolt 5 x 28	1	017502-803			
47- 4	Stud (A)	1	147855-001	147899-011	53-16	Washer 5	2	025050-233		

INDEX/VERZEICHNIS INDEX/INDICE

Parts No.	Ref. No.	Remark	Parts No.	Ref. No.	Remark	Parts No.	Ref. No.	Remark	Parts No.	Ref. No.	Remark
S00096-001	Z- 23- 2		025350-332	M-22		081007-070	H- 71		102571-003	J- 16	
S00150-001	E- 70		025350-332	V- 6- 7		081014-670	H- 7			M-12- 3	
S00839-001	F- 14		025680-133	Z- 44		081062-090	V- 1-13		102630-001	C-24	
S00841-001	F- 14		025680-232	M-12- 4		100022-004	G- 5			R-26	
S00879-001	F- 9- 1		025750-132	Z- 47- 9		100032-004	C- 27		102716-001	H-36	
S00896-000	J- 52			Z- 92		100080-003	E- 70-10		102843-004	J- 5	
S00897-000	J- 52- 1		028040-243	S- 1- 9		100090-004	A- 7		103738-001	V- 1-24	
S00899-000	J- 52- 2			U- 1- 8		100128-002	F- 13		103950-003	B- 21	
S00899-000	C- 10		028050-243	Q- 1-15			V- 1-12		104449-001	A-11	
S01230-001	C- 10			Z- 53- 9		100136-001	B- 35- 8			H- 2	
S01277-001	M-12		028060-242	R- 3			V- 6- 5		104450-001	A-13	
001061-606	U- 1-10			U- 1-12		100251-001	C- 8- 2		104451-001	A-24	
001670-512	L- 48		028680-242	Z- 47- 7			C-10- 2		104464-001	C- 11	
001670-612	K- 9		031452-203	Z- 53- 2			D- 1- 1- 2		104520-000	D-11	
	K-13		031483-203	T- 14			D- 1- 2- 2		104547-001	H- 4	
	V- 6- 6		034422-503	S- 2			D- 2- 1- 2		104564-001	H-26	
001671-012	F- 8		048030-342	K- 5			D- 2- 2- 2		104567-001	E- 71- 3	
002300-805	T- 10- 1-11			R-23			E- 27		104619-002	G- 8- 4	
002501-003	Q- 1-14		048040-342	F- 17			E- 29		104689-002	E- 4	
007300-612	L- 37			M-12- 8			E-35			E- 39	
	L- 39			N- 8			E- 37		104821-001	A-19	
007500-602	N- 10			R- 7			J- 27		104829-101	A- 4	
007500-812	N- 3			R-28		100257-010	H- 6		104830-101	A- 5	
009679-312	Z- 45-22		048060-342	J- 33			Z- 94		104832-001	A-18	
009681-612	E- 71- 5		048080-342	E- 14		100260-001	C- 20		104847-001	E- 26	
009781-812	N- 2		048090-342	L- 32		100265-031	C- 22			E- 34	
	N-14		062670-412	E- 52			Z- 8		104848-001	E- 28	
013670-712	J- 48		062670-512	H- 11		100265-034	C- 22			E- 36	
013760-610	C- 5		062670-516	E- 15		100265-431	Z- 8		104885-001	G- 4	
	C- 7			H-66		100265-442	Z- 8		105234-003	J- 26	
	D- 5		062670-612	B- 26		100267-001	Z- 8		107149-001	H-20	
013760-612	R- 24			C- 35		100268-004	C- 30- 1		107155-001	H-34	
	C- 32			K- 11		100328-001	E- 22		107428-003	E- 32- 2	
	D- 7			L- 50		100334-001	E- 70- 9		108520-001	A-23	
013781-012	C- 15			M-11		100366-002	V- 1-18		108549-001	E- 17- 6	
014680-422	L- 44		062670-812	A- 10			V- 1-20		108801-001	E- 70-13	
014680-622	J- 38			H-49- 5			Z- 45-13		108802-001	E- 71- 4	
014710-522	F- 26			H-75		100367-001	D- 15		108804-001	H-14	
014771-022	J- 3			H-77		100398-001	B- 35- 2		108960-002	B- 33	
017502-803	Z- 53- 7			K- 7		100400-000	B- 20		109147-001	E- 2	
	Z- 53-15			M-13		100401-001	V- 6- 4		109151-101	E- 17- 1	
017761-412	R- 29		062671-012	B- 31			Z- 45- 4		109152-001	E- 70- 2	
017762-013	G- 8- 3		062671-612	B- 30		100402-004	B- 35- 3		109153-001	E- 49	
	R- 10		062680-616	Z- 43		100463-001	G- 8- 2		109173-001	H- 29	
021060-206	U- 1-13		062680-712	B- 24			R- 9		109268-001	U- 1-14	
021080-302	R- 31			B- 28			S- 1- 3		109405-001	H-10- 2	
021400-164	S- 1-10			H- 59		100477-001	Z- 19		109714-000	Z- 31	
	T- 10- 1-18			J- 7		100511-003	E- 11		109763-002	F- 16	
	T- 10- 1-28		062680-812	Z- 47- 6		100573-001	B- 34		110087-001	G- 8- 7	
021500-103	Z- 53- 4- 3			Z- 96		100645-003	J- 10			S- 1- 5	
	Z- 53-10		062681-012	L- 40			J- 50		110161-004	K- 3	
021500-104	U- 1- 4			M-12- 7			L- 51		110201-001	J- 39	
025030-135	P- 3-14		062681-212	D-16			L- 52			P- 2	
025030-335	P- 3- 4			E- 24		100656-001	Z- 45-14		110367-001	C- 16	
	T- 10- 1-12		062680-512	V- 1- 8		100657-001	Z- 45-15			J- 32	
025040-135	P- 3-16			V- 1-23		100659-001	Z- 45-17		111234-101	C- 14	
025040-233	S- 1- 8		062710-812	E- 58		100662-001	Z- 45-20		111443-003	L- 46	
	T- 10- 1-17		062711-412	E- 5- 2		100666-002	Z- 46		111462-001	C- 21	
	T- 10- 1-27			E- 9			Z- 47- 8		111463-001	C- 17	
025040-335	P- 3-12			J- 19			Z- 91		111466-001	F- 1	
	P- 3-20			P- 1		100887-001	Z- 4- 1		111469-101	B- 23	
025050-233	U- 1- 5			R- 17		101118-001	Q- 3		111476-001	B- 32	
	Z- 53-16		062760-812	Z- 93		101487-000	H- 17		111863-001	H- 28	
025060-232	R- 30		062761-212	R- 15		101572-101	Z- 3- 5		111865-001	H- 13	
025060-236	U- 1-11			R- 21		101706-001	D- 13- 2		112467-002	H- 49- 8	
025100-132	E- 13		081001-670	H- 21			D- 14- 2		112525-000	Z- 20	
025350-132	F- 29			H- 81		101706-003	G- 13		113730-001	L- 41	

Parts No.	Ref. No.	Remark	Parts No.	Ref. No.	Remark	Parts No.	Ref. No.	Remark	Parts No.	Ref. No.	Remark
114294-001	B- 35- 9		143485-001	R-13- 4		145597-001	Z- 95		147853-001	Z- 47- 1	
114561-001	C- 30- 2		143488-001	Q- 1-10		145600-000	C-14- 3		147854-001	Z- 47- 2	
114908-001	C- 21		143489-001	Q- 1-11		145624-000	C-14-10		147855-001	Z- 47- 4	
114966-001	G- 8- 5		143499-000	S- 11- 2- 2		145688-000	C- 34		147856-001	Z- 47- 5	
114967-001	G- 8- 6		143500-000	T- 10- 1-14-2		145690-001	F- 14- 2		147899-011	Z- 47	
	S- 1- 4		143501-000	T- 10- 1-21		145691-001	B- 22		148350-101	D-18	
116662-003	E- 57		143548-000	S- 1-11- 2-4		145737-001	H-67		148512-000	L- 31	
116794-001	H-33			T- 10- 1-13-3		145751-001	H-30		148518-000	L- 35	
117132-001	D-19			T- 10- 1-14-3		145945-001	Z- 27		148537-001	J- 13	
	Z- 10			T- 10- 1-22		145946-001	Z- 42		148546-001	L- 34	
117442-001	E- 70- 6		143549-000	M- 3- 3		145986-001	C-21		148822-001	C-31	
117963-001	Z- 45			N- 4- 5		146003-101	Z- 29		148823-001	C-31	
117969-001	Z- 45-10			Q- 1-13		146004-001	Z- 30		148825-001	P- 6	
117970-001	Z- 45-11			R-13- 5		146036-101	G- 1		148849-001	H-49- 3	
118216-000	E- 71- 2- 3			S- 1-11- 1-2		146037-001	G- 2		148924-101	B- 35- 7	
118558-001	H-74			S- 1-11- 2-5		146038-001	G- 6		148967-101	D-18- 4	
118559-001	H-76			T- 10- 1-15-5		146039-001	G- 8- 1		149083-001	E- 12	
118735-002	V- 1-10		143549-001	L- 30- 2			R- 8		149085-001	E- 53	
118761-000	D- 9		143910-001	Z- 28		146040-001	H-69		149086-001	E- 54	
118762-000	D-20		144222-001	Z- 52		146049-001	Z- 4-11		149087-001	E- 55	
118768-001	C- 14-11		144500-001	E- 70- 9		146069-001	G- 1		149088-001	E- 56	
118837-001	Z- 3- 3		144504-001	B- 1- 2		146080-000	J- 41		149089-001	N-11	
120990-001	E- 70- 6		144615-001	Z- 32			M- 8		149094-001	N-12	
122771-002	C- 30- 3		144869-002	H-49- 2		146092-001	L- 17		149095-001	N-13	
122991-001	Z- 1		144872-001	H-56		146094-001	L- 20		149135-101	K-12	
123006-001	E- 59- 2		144874-001	H-49- 4		146103-001	N- 4- 3		149140-101	N- 1	
125925-002	D- 10		144875-001	H-49- 6		146104-000	N- 4- 4		149168-001	Z- 45- 6	
126863-000	Z- 53-13		144876-001	H-49- 7		146105-000	N- 9		149313-101	C- 14	
140004-001	C- 14- 6		144878-001	H-49- 9		146118-000	S- 1-11- 3		149411-001	T- 10- 2	
140378-001	D- 1		145157-001	F- 7		146119-000	S- 1-11- 4		149578-000	H-68- 1	
140381-001	D- 2		145446-001	B- 35- 5		146124-001	M- 4		149580-001	H-68	
140503-001	G- 8- 8			V- 6- 3		146157-001	R- 1		149581-101	H-68	
140518-001	H-70			Z- 45- 3		146175-001	U- 1		149799-000	S- 1-12	
140540-000	Q- 1- 9		145454-001	A- 6		146178-001	U- 1- 2		150106-001	Z- 53- 4	
140543-000	Q- 1- 7		145455-002	A- 8		146196-001	H-73		150139-001	Z- 53- 1	
140553-102	C- 23		145459-001	C- 2		146244-000	T- 10- 1-20		150150-003	Z- 53	
140627-001	R- 5		145461-101	C- 6		146253-000	H-78		150172-001	Z- 53- 3	
140643-000	M- 3- 1		145465-001	C- 14- 2		146288-001	L- 22		150178-001	Z- 53- 6	
140647-001	J- 42		145468-001	C- 19		146289-001	Z- 47- 1- 1		150179-001	Z- 53- 8	
	M-10		145472-001	F- 2		146293-001	G- 7		150180-000	Z- 53-11	
140668-001	R- 4		145474-001	F- 12		146314-000	H- 9		150181-101	Z- 53- 1- 2	
140726-000	C- 4		145475-101	F- 15		146327-001	H-19		150182-000	Z- 53-12	
140885-005	B- 27		145478-001	F- 21		146333-001	H-18		150184-001	Z- 53-14- 5	
140923-000	T- 10- 1-25		145479-001	F- 22		146358-001	U- 1-15		150189-001	Z- 53- 1- 1	
140947-002	U- 1- 6		145480-001	F- 23		146367-001	G- 3		150192-003	Z- 53-14	
140953-001	U- 1- 3		145481-001	F- 24		146986-001	R- 6		150202-001	Z- 53- 4- 2	
141032-000	T- 10- 1- 6		145482-001	F- 25		147141-001	R- 2		150340-000	E- 70-12	
141033-001	T- 10- 1- 5		145483-001	F- 27		147197-101	F- 15		150342-001	E- 70-11	
141207-001	F- 3		145486-001	E- 3- 3		147245-001	C-26		150384-001	F- 28	
141208-001	F- 4		145502-001	E- 21		147496-000	H-60		150792-001	Z- 8	
141351-001	G-12		145506-001	E- 32		147500-000	E- 48		151063-001	E- 1	
142026-003	S- 1- 1		145516-001	D- 3		147503-001	E- 8		151074-001	H- 5	
142027-001	S- 1- 2		145519-001	B- 35- 4		147505-001	E- 10		151126-101	Q- 1	
142037-000	Q- 1- 5					147509-001	E- 38		151127-100	Q- 1- 2	
142038-001	Q- 1- 6		145522-001	B- 25		147510-001	E- 71- 1		151147-001	Q- 1- 4	
142116-001	C- 19		145523-102	B- 29		147511-001	C- 1		151153-101	Q- 1- 1	
142268-001	L- 25		145527-000	H- 1		147514-001	F- 5		151154-000	Q- 2	
142274-001	A- 22		145528-000	H- 3		147551-101	C- 14		151181-001	N- 4	
142443-001	Z- 3- 1		145529-000	H- 8		147557-101	B- 4		151507-001	E- 17- 3	
142566-001	V- 1-17		145534-001	H-32		147568-001	V- 1- 3		151508-001	E- 17- 3	
142708-000	D- 4		145543-001	H-64		147573-001	E- 1		151594-001	C- 25	
142709-000	D- 6		145547-001	H-65		147598-001	E- 7		151601-002	E- 70- 3	
142721-001	Z- 90		145571-101	V- 6- 2		147632-000	Z- 47- 3		151602-002	B- 3	
142746-002	E- 17- 4		145573-000	Z- 23		147756-001	N- 4		151604-001	E- 1-3	
142747-002	E- 17- 5		145580-001	F- 10		147764-001	E- 51			F- 9- 2	
142990-001	Z- 53-14- 4		145596-001	J- 44- 1		147767-001	E- 70- 4		151607-001	D-12	
143484-000	R- 13- 4			N- 6		147777-000	C- 14- 9			J- 23	

Parts No.	Ref. No.	Remark	Parts No.	Ref. No.	Remark	Parts No.	Ref. No.	Remark	Parts No.	Ref. No.	Remark
151987-001	J- 15		154593-001	J- 28		159473-001	C- 10				
153037-101	F- 7		154594-000	J- 29		159753-001	L- 30				
153116-000	R- 12		154595-001	J- 30		159805-001	B- 35- 6				
153117-001	R- 13		154596-000	J- 31		159960-001	T- 10- 1-14				
153118-000	R- 13- 1		154597-001	J- 34		159961-001	T- 10- 1-15				
153119-001	R- 13- 2		154598-001	J- 35		159962-000	T- 10- 1-13				
153120-001	R- 14		154599-000	J- 36		159966-000	T- 10- 1-15-3				
153121-001	R- 16		154600-001	J- 37		180018-001	C- 30				
153122-000	R- 18		154601-001	K- 1		181427-001	G- 8				
153123-001	R- 20		154602-001	K- 2		181476-201	H- 49				
153124-001	R- 22		154603-001	K- 4		181482-101	E- 17				
153127-001	G- 1		154606-001	K- 6		181632-101	E- 17				
153128-001	G- 11		154607-001	K- 8		181634-001	B- 35				
153131-001	D- 17		154608-001	K- 10		181639-001	H- 10				
153138-001	N- 26		154702-001	Z- 51		181916-001	C- 8				
153155-000	T- 10- 1- 7		155347-001	K- 14		181935-001	E- 5				
153156-001	T- 10- 1- 9		155510-001	B- 1- 4		181941-001	E- 71- 2				
153157-000	T- 10- 15		155558-001	J- 40		181995-001	D- 13				
153159-001	T- 10- 1- 14		155559-001	J- 47			D- 14				
153160-001	T- 10- 15		155578-000	J- 49		183117-001	E- 71				
153162-000	T- 11		155688-001	E- 1		183124-001	B- 1				
153163-001	T- 12		155690-001	D- 17		183125-001	B- 1				
153164-001	T- 13		156246-001	E- 70- 5		183129-001	B- 35				
153165-000	T- 10- 1- 23		156479-000	M- 18- 2		183175-001	B- 35				
153168-001	E- 17- 2		156531-001	A- 9		183178-001	E- 59				
153190-001	C- 26		156113-001	Z- 12		183196-001	E- 70				
153198-001	R- 25		156116-001	Z- 8		183197-001	E- 70				
153245-001	N- 7		156626-001	J- 34		183200-001	E- 70				
	R- 27		156634-001	E- 3		183226-001	V- 6				
153969-000	J- 45		156641-001	H- 22		183291-001	D- 18- 1				
153970-001	J- 46		156945-101	F- 27		183292-001	D- 18- 2				
153971-001	J- 46- 12		156988-001	L- 30		183293-001	D- 18- 3				
154169-001	S- 1		156990-001	L- 33		183294-001	F- 9				
154170-001	S- 1- 6		156991-001	L- 36		200190-001	Q- 4				
154172-001	S- 11- 2		156992-001	L- 38			T- 15				
154201-001	N- 4		156993-001	L- 42		212251-001	U- 1- 7				
154206-000	M- 3		156994-001	L- 43		215080-001	P- 3- 17				
154214-001	Q- 1- 8		156995-001	L- 45			P- 3- 21				
154215-001	Q- 1- 12		156996-001	L- 47			T- 10- 1- 4				
154293-001	T- 10		156997-001	M- 12- 1			T- 10- 1- 8				
154294-001	T- 10		156998-001	M- 12- 6			P- 10- 1- 26				
154296-001	T- 10- 3- 2		156999-001	M- 12- 5		215083-001	P- 3- 5				
154367-001	S- 1- 11		157000-001	M- 18- 1			P- 3- 15				
154550-001	F- 20		157953-001	V- 1		216332-001	P- 5				
154552-001	D- 8		157956-001	V- 1- 2		216351-001	T- 10- 1- 10				
154554-001	H- 35		157957-001	V- 1- 4		216365-001	T- 10- 1- 19				
154555-001	H- 61		157958-001	V- 1- 3		217093-001	P- 3- 13				
154559-001	B- 1- 1			V- 1- 5		218944-001	P- 4				
154560-001	B- 1- 3		157959-001	V- 1- 7		219557-000	P- 3- 6				
154562-001	B- 1- 3		157960-001	V- 1- 9		219558-000	P- 3- 7				
154563-001	B- 2		157961-000	V- 1- 11		219559-001	P- 3- 8				
154566-001	J- 1		157962-001	V- 1- 14		219591-001	T- 10- 1- 15- 4				
154567-000	J- 2		157963-001	V- 1- 15		219600-001	T- 10- 1- 15- 2				
154568-001	J- 4		157964-001	V- 1- 16			T- 10- 1- 24				
154569-001	J- 6		157966-001	V- 1- 19		219696-000	P- 3- 11				
154570-001	J- 8		157967-001	V- 1- 21		221421-001	P- 3- 9				
154571-001	J- 9		157968-001	V- 1- 22		222379-001	P- 3				
154574-001	J- 11		157969-001	V- 2		224339-001	P- 3				
154575-001	J- 12		157970-001	V- 4		340400-001	J- 51				
154576-001	J- 14		157971-001	V- 6- 1							
154577-001	J- 17		157986-001	V- 1- 6							
154578-000	J- 18		157999-001	M- 12- 9							
154579-001	J- 20		158381-001	L- 30							
154580-001	J- 21		158677-001	R- 19							
154581-001	J- 22		158727-001	C- 14- 12							
154582-001	J- 24		159324-001	D- 15							
154590-001	J- 25		159430-001	Z- 12							

**GAUGE PARTS LIST/LISTE DES PIECES DÉCARTEMENT
LEHREN LISTE/LISTA DE PIEZAS CALIBRADORAS**

Feed Dog	Needle Plate	Presser Foot Assembly	
S00868-001	S00867-001	153037-101	
	S01107-001		
	S01127-001		
	S01127-001		
S01108-001	S00867-001	153037-101	
	S01107-001		
	S01126-001		
	S01127-001		
100344-001	100266-001	113280-001	140957-001
	100267-001		
	111241-001		
	145971-001		
	146050-001		140957-001
	146232-001		
	147238-001		
	147239-001		140957-001
153190-001			
117442-001	100266-001	113280-001	
	141096-001		
144500-001	100267-001	145157-001	
	111241-001		
	145971-001	113280-001	
	147245-001	145157-001	
	147322-001 153147-001		
146231-001	146232-001	113280-001	
	146233-001		140957-001
	153147-001		
155675-001	155676-001	111856-001 • 143711-001	
156113-001	156114-001	113280-001 • 140957-001 • 153037-101	
	156115-001		
	156116-001		
159430-001	150792-001	150789-001	

Feed Dog	S00868-001 	S01108-001 	I00334-001 	I17442-001
	I44500-001 	I46231-001 	I55675-001 	I56113-001

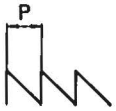

I59430-001

Presser Foot Assembly	c-1	I11856-001 	c-2	I13280-001 		
	c-3	I40957-001 	c-4	I43711-001 		
	c-5	I45157-001 	c-6	I53037-101 	c-7	I50789-001

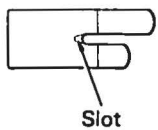

Needle Plate

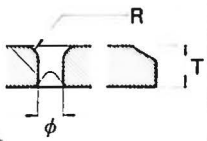

<p>S00867 001</p> <p>Medium</p> <p>100266-001</p>	<p>S01107-001</p> <p>Thin</p> <p>100267-001</p>	<p>S01126 001</p> <p>Thin</p> <p>111241-001</p>	<p>S01127 001</p> <p>Medium</p> <p>141096-001</p>
<p>B18</p> <p>Medium</p> <p>145971-001</p>	<p>B22</p> <p>Thick</p> <p>146050-001</p>	<p>B26</p> <p>Thick</p> <p>146232-001</p>	<p>H18</p> <p>Medium</p> <p>146233-001</p>
<p>B18</p> <p>Medium</p> <p>147238-001</p>	<p>B14</p> <p>Thin</p> <p>147239-001</p>	<p>B18</p> <p>Medium</p> <p>147245-001</p>	<p>B14</p> <p>Thin</p> <p>147322-001</p>
<p>B14</p> <p>Thin</p> <p>150792-001</p>	<p>B16</p> <p>Medium</p> <p>153147-001</p>	<p>B26</p> <p>Thick</p> <p>153190-001</p>	<p>C26</p> <p>Thick</p> <p>155676-001</p>
<p>H26</p> <p>Thick</p> <p>156114-001</p>	<p>B12</p> <p>Thin</p> <p>156115-001</p>	<p>B16</p> <p>Medium</p> <p>156116-001</p>	
<p>AB14</p> <p>Thin</p>	<p>AB16</p> <p>Medium</p>	<p>AB18</p> <p>Medium</p>	

